

HPV2M SERIES – HIGH PRESSURE HIGH SPEED SINGLE PUMPS

These HPV2M pumps are designed for high-pressure applications. Suitable for mobile applications like Cranes, Pressure Die Castings, Hydraulic Presses, Railways & Construction Equipments.

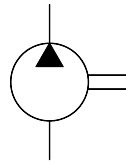

Graphic Symbol



Specifications

Model Number	Y	Nominal Delivery	Geometric Displacement cm ³ /rev.	Max. Oper. Pressure Kg/cm ²	Output Flow and Input Power	Shaft Speed Range r/min.		Mass (Approx.) Kg.	
						Max.	Min.	Flange Mtg.	Foot Mtg.
HPV2M	Port Connection	03	10.8	280	Ref. Page Nos. 179, 180, 181 & 182	2800	400	15.5	19.8
		05	17.2						
		06	21.3						
		08	26.4						
		10	34.1						
		12	37.1						
		14	46.0						
		15	50.5						
		17	58.3						
		20	63.8						
		22	70.3						
		25	79.3						
		28	88.8						
				31		100.0	210		2500

Model Number Designation

HPV2M	Y	-12	-F	-R	A	A	-K1	-20
Model Number	Port connection	Nominal Delivery	Type of Mounting	Direction of Rotation	Discharge Port Position	Suction Port Position	Type of Shaft	Design * No.
					As viewed from shaft end			
HPV2M	Y: Metric port connection (Omit for UNC.)	03 05 06 08 10 12 14 15 17 20 22 25 28 31	F: Flange Mtg. L: Foot Mtg.	R: Clockwise (Normal) L: Anti-clockwise			K1- Keyed (SAE-B) K2- Keyed S1- Splined (SAE-B) S2- Splined (SAE BB)	20

* Design numbers subject to change from 10 to 29, but installation dimensions remain as shown.

* For instructions regarding changing the port positions, consult YUKEN INDIA LTD.

■ Cartridge Kit Model Number

CHPV2M	-12	-R	-20
Model Number	Nominal Delivery	Shaft Rotation	Design No.
CHPV2M	03	R: Clockwise (Normal)	20
	05		
	06		
	08		
	10		
	12		
	14	L: Anti- Clockwise	
	15		
	17		
	20		
	22		
	25		
28			
31			

* For instructions regarding replacing cartridge kit, consult YUKEN INDIA LTD.

■ Spare Parts List

● List of Seals

Sl. No.	Name of Part	Part Number	Qty.
1	O-Ring	PKH4-0290	1
2	O-Ring	PKH4-0289	1
3	O-Ring	PKH4-0288	1
4	Backup-Ring	PKH4-0184	1
5	Oil Seal (Viton)	25.4x38.1x6.35	1

Note : When ordering the seal kit, please specify the Kit number KS-HPV2-10.

● Foot Mounting Parts

Sl. No.	Name of Part	Part Number	Qty.
1	Mounting Bracket	PK2-10513-8	1
2	Socket Head Cap Screw	M12 x 35Lg.	2
3	Spring Washer	WS-A-12	2

Note : When ordering the Foot Mounting Parts, please specify the Kit number HPV2-L-10.

Flanges

Threaded Type

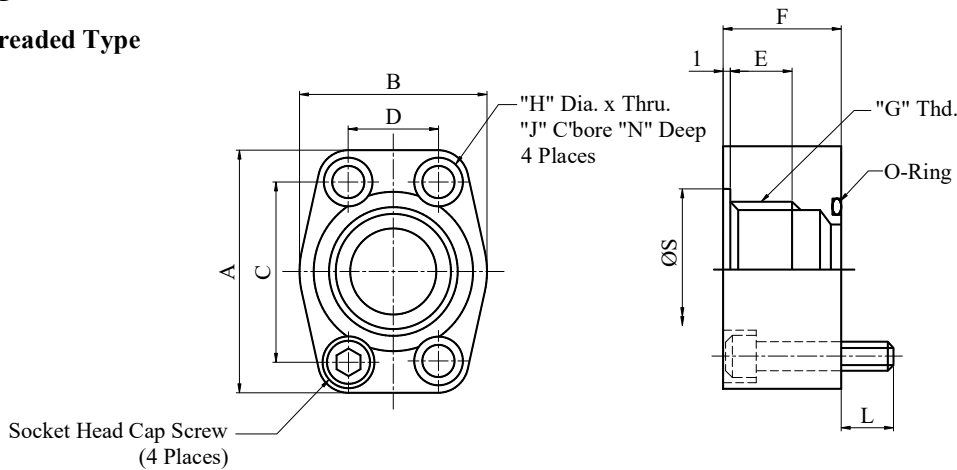

Kit Numbers	Piping Size "G" Thd.	Dimensions mm											Socket Head Cap Screw (4 Places)	O-Ring
		A	B	C	D	E	F	H	J	N	L	S		
HPV-F-0.75-U-T-10	3/4" BSP.F	72	53	47.6	22.2	20	28	11	17.5	11	18	35.5	3/8-16TPI UNC x 1-1/2 M10 x 35Lg.	SO-NB-G30
HPV-F-0.75-M-T-10														
HPV-F-1-U-T-10	1" BSP.F	73	50	52.4	26.2	21	30	11	15.5	11.5	16.5	43.5	3/8-16TPI UNC x 1-1/2 M10 x 35Lg.	SO-NB-G35
HPV-F-1-M-T-10														
HPV-F-1.25-U-T-10	1-1/4" BSP.F	85	56	58.7	30.2	24	38	13.5	20	13.5	20	53	7/16-14TPI UNC x 1-3/4 M12 x 45Lg.	SO-NB-G40
HPV-F-1.25-M-T-10														
HPV-F-1.5-U-T-10	1-1/2" BSP.F	96	72	69.9	35.8	24	30	13.5	21	14.5	19.5	59	1/2-13TPI UNC x 1-1/2 M12 x 35Lg.	SO-NB-G50
HPV-F-1.5-M-T-10														
HPV-F-2-U-T-10	2" BSP.F	105	77.5	77.8	42.9	24	32	13.5	21	13.5	19.5	73.5	1/2-13TPI UNC x 1-1/2 M12 x 40Lg.	SO-NB-G65
HPV-F-2-M-T-10														
HPV-F-2.5-U-T-10	2-1/2" BSP.F	118	102	88.9	50.8	31	46	13.5	21	13.5	18	86	1/2-13TPI UNC x 2 M12 x 50Lg.	SO-NB-G75
HPV-F-2.5-M-T-10														
HPV-F-3-U-T-10	3" BSP.F	138	138	106.4	62	30	41	17.5	26	17.5	26.5	100	5/8-11TPI UNC x 2 M16 x 50Lg.	SO-NB-G90
HPV-F-3-M-T-10														

Welding Type

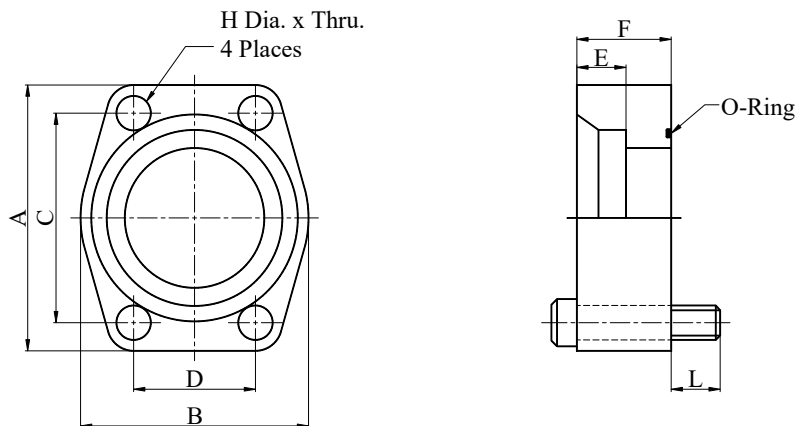

Kit Numbers	Piping Size "G" Thd.	Dimensions mm								Socket Head Cap Screw (4 Places)	O-Ring
		A	B	C	D	E	F	H	L		
HPV-F-0.75-U-W-10	3/4" BSP.F	65	48	47.6	22.2	12	30	11	15	3/8-16TPI UNC x 1-3/4 M10 x 45Lg.	SO-NB-G30
HPV-F-0.75-M-W-10											
HPV-F-1-U-W-10	1" BSP.F	70	55	52.4	26.2	14	30	11	15	3/8-16TPI UNC x 1-3/4 M10 x 45Lg.	SO-NB-G35
HPV-F-1-M-W-10											
HPV-F-1.25-U-W-10	1-1/4" BSP.F	80	64	58.7	30.2	16	38	13.5	22	7/16-14TPI UNC x 2-1/4 M12 x 60Lg.	SO-NB-G40
HPV-F-1.25-M-W-10											
HPV-F-1.5-U-W-10	1-1/2" BSP.F	94	72	69.9	35.8	18	38	13.5	17	1/2-13TPI UNC x 2-1/4 M12 x 55Lg.	SO-NB-G50
HPV-F-1.5-M-W-10											
HPV-F-2-U-W-10	2" BSP.F	102	85	77.8	42.9	20	38	13.5	22	1/2-13TPI UNC x 2-1/4 M12 x 60Lg.	SO-NB-G65
HPV-F-2-M-W-10											
HPV-F-2.5-U-W-10	2-1/2" BSP.F	114	102	88.9	50.8	22	48	13.5	17	1/2-13TPI UNC x 2-3/4 M12 x 65Lg.	SO-NB-G75
HPV-F-2.5-M-W-10											
HPV-F-3-U-W-10	3" BSP.F	135	116	106.4	62	25	48	17.5	27	5/8-11TPI UNC x 3 M16 x 75Lg.	SO-NB-G90
HPV-F-3-M-W-10											

HPV2M Series Single Vane Pumps

● HPV2M-03

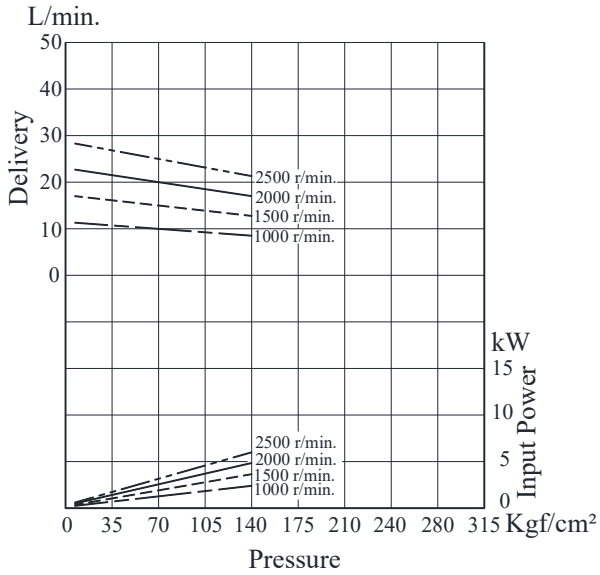

● HPV2M-05

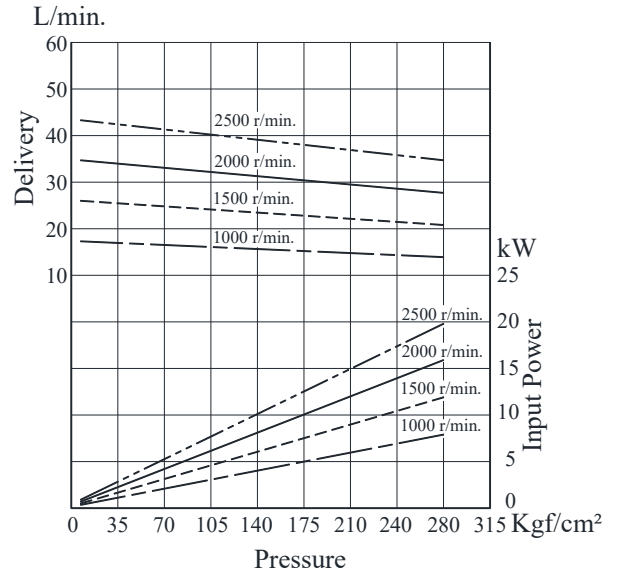

● HPV2M-06

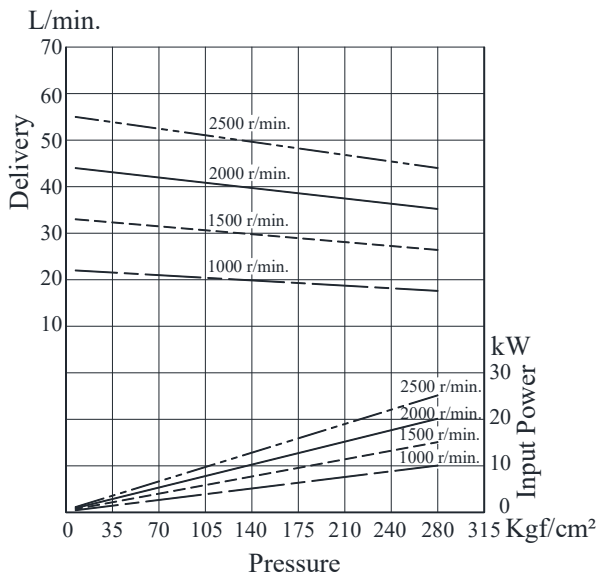

● HPV2M-08

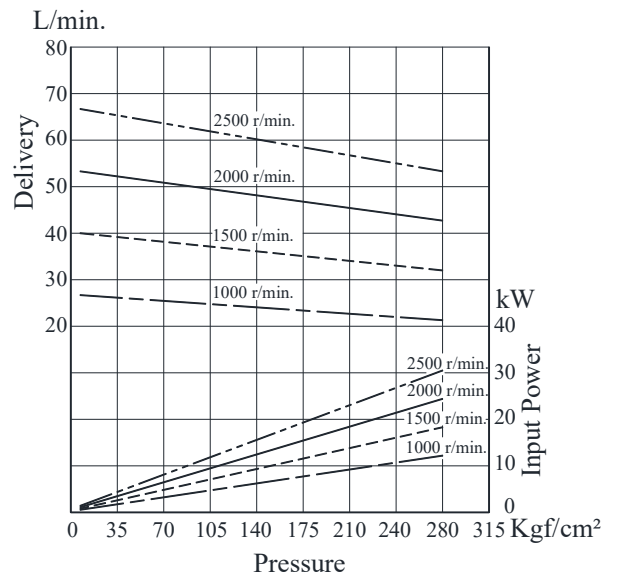

Typical Pump Characteristics Oil Viscosity 20 cSt [ISO VG 32, Temp 50°C]

● HPV2M-10

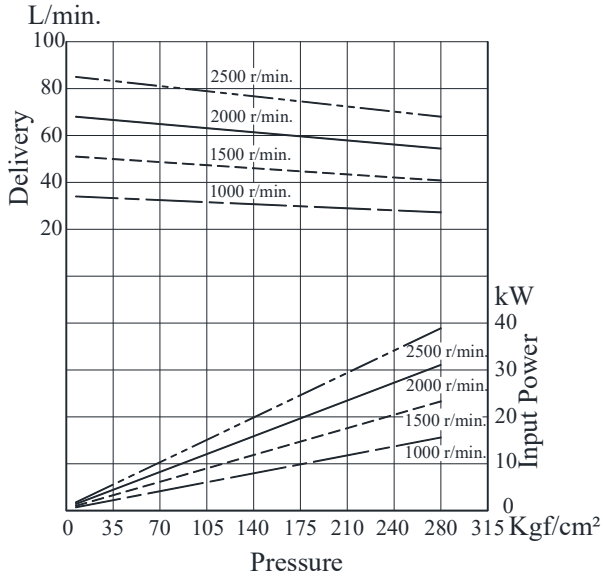

● HPV2M-12

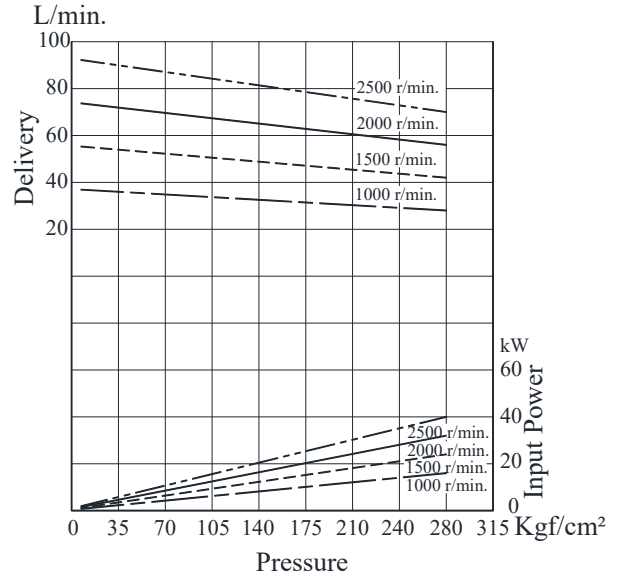

● HPV2M-14

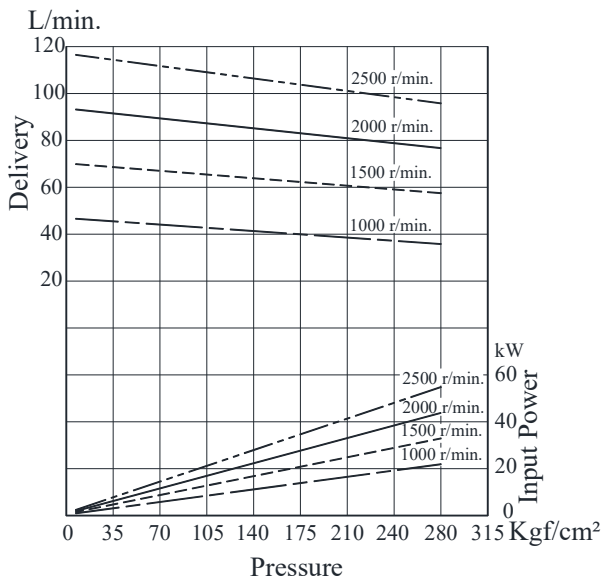

● HPV2M-15

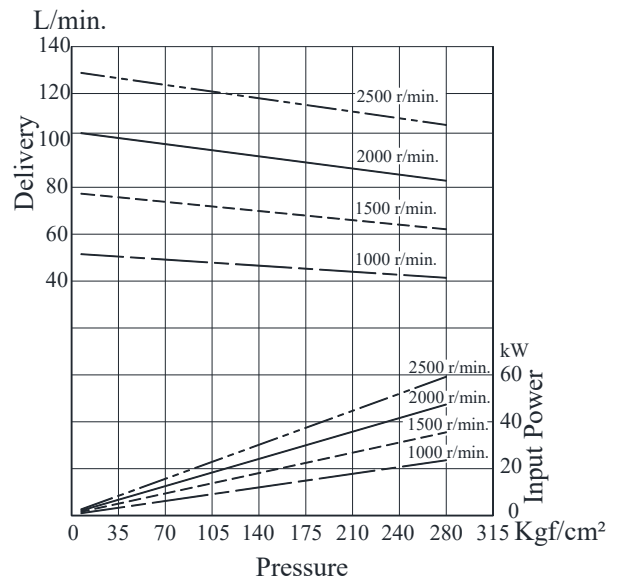

HPV2M Series Single Vane Pumps

Typical Pump Characteristics Oil Viscosity 20 cSt [ISO VG 32, Temp 50°C]

● HPV2M-17

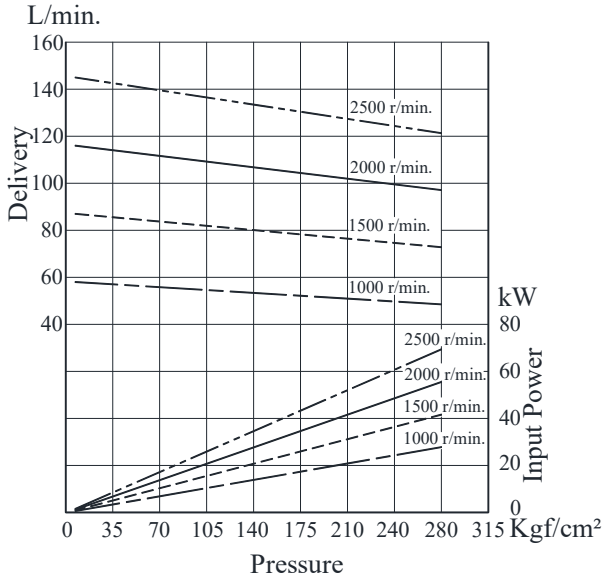

● HPV2M-20

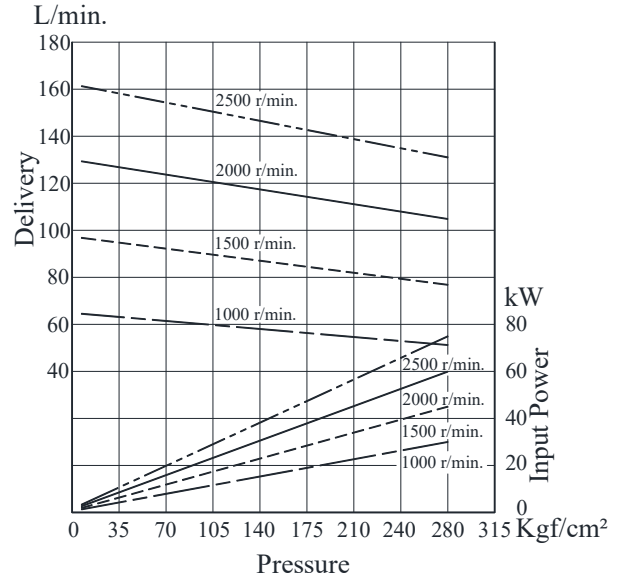

● HPV2M-22

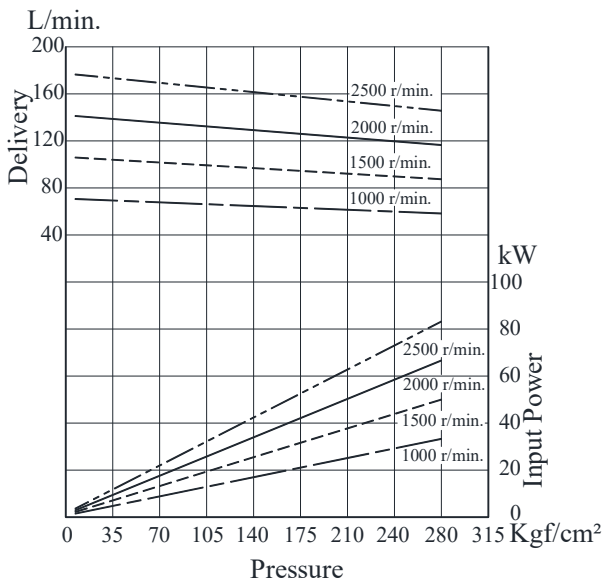

● HPV2M-25

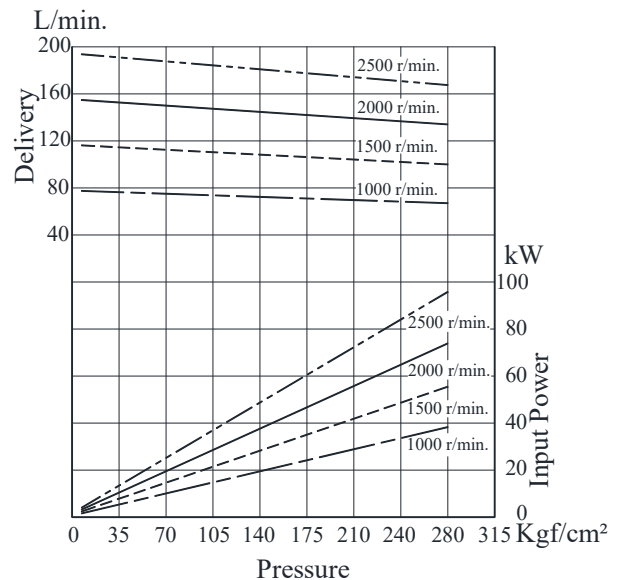

B
HPV Series
Single Vane Pump

Typical Pump Characteristics Oil Viscosity 20 cSt [ISO VG 32, Temp 50° C]

● HPV2M-28

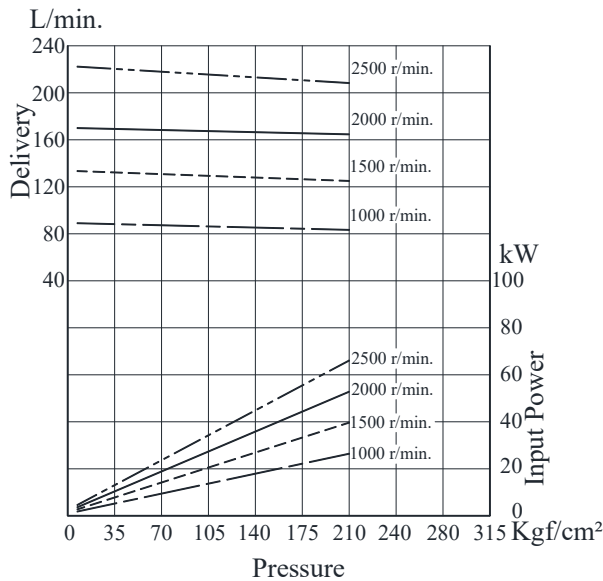

● HPV2M-31

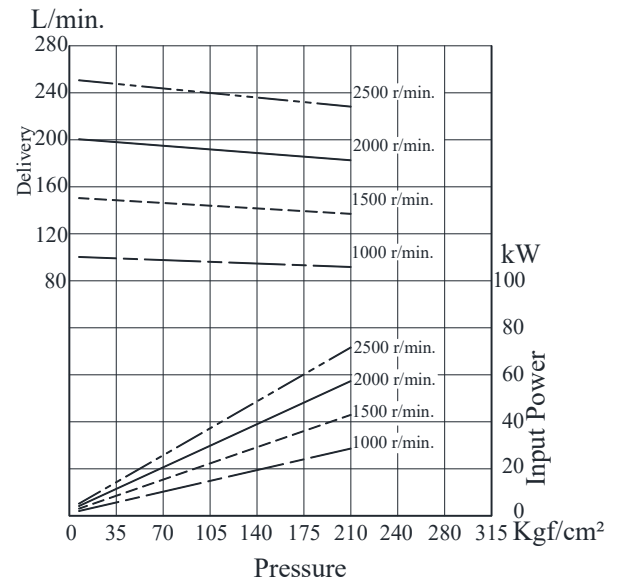

■ Hydraulic Fluids

● Suction Pressure

Suction line pressure limit -0.20Kgf/cm² to +0.3Kgf/cm²

● Cleanliness

Contamination level should be within NAS class 9. The return line must have a line type filter of under 10µm or there should be an offline/independent filtration unit in the system.

● Alignment of Shaft

Employ a flexible coupling whenever possible & avoid stress from bending or thrust. Maximum permissible misalignment is less than 0.1mm(0.004 inches) TIR & maximum permissible misangular is less than 0.2°.

■ Instructions

● Precautions at starting

At an initial operation or at an operation after a long rest, the pump may have difficulty in sucking up fluids. In such cases, an air bleed valve should be installed before hand in the discharge side (Model No.ST1001-※-10※), or discharge air by slightly slackening the connection on the discharge side. At starting, operate the pump intermittently as far as possible with no load.

● Other Precautions

If a pump is used at speed below 1200 r/min., install the pump with the suction port upside so that the pump can suck up fluid easily at starting.

HPV3M SERIES – HIGH PRESSURE HIGH SPEED SINGLE PUMPS

These HPV3M pumps are designed for high-pressure applications. Suitable for mobile applications like drill rigs, Railways & Construction Equipments.

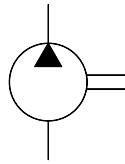

Graphic Symbol



B

HPV Series
Single Vane Pump

Specifications

Model Number	Y	Nominal Delivery	Geometric Displacement cm ³ /rev.	Max. Oper. Pressure Kg/cm ²	Output Flow and Input Power	Shaft Speed Range r/min.		Mass (Approx.) Kg.			
						Max.	Min.	Flange Mtg.	Foot Mtg.		
HPV3M	Port Connection	14	47.6	240	Ref. Page Nos. 186, 187 & 188	2500	400	24.0	32.3		
		17	58.2								
		20	66.0								
		24	79.5								
		28	89.7								
		31	98.3								
		35	110.0								
		38	120.3								
		42	136.0								
		45	145.7								
				50	158.0	210					
				61	190.5	80		2200			

Model Number Designation

HPV3M	Y	-38	-F	-R	A	A	-K1	-10		
Model Number	Port connection	Nominal Delivery	Type of Mounting	Direction of Rotation	Discharge Port Position	Suction Port Position	Type of Shaft	Design* No.		
					As viewed from shaft end					
HPV3M	Y: Metric port connection (Omit for UNC.)	14	F: Flange Mtg.	R: Clockwise (Normal)	L	A	K1- Keyed (SAE-C)	10		
		17								
		20								
		24								
		28								
		31								
		35								
		38								
		42								
		45								
				50	L: Foot Mtg.	L: Anti-clockwise	L		A	S1- Splined (SAE-C)
				61						

* Design numbers subject to change from 10 to 19, but installation dimensions remain as shown.

* For instructions regarding changing the port positions, consult YUKEN INDIA LTD.

Cartridge Kit Model Number

CHPV3M	-14	-R	-10
Pump Series	Nominal Delivery	Shaft Rotation	Design Number
CHPV3M	14	R: Clockwise (Normal) L: Anti- Clockwise	10
	17		
	20		
	24		
	28		
	31		
	35		
	38		
	42		
	45		
	50		
61			

* For instructions regarding replacing cartridge kit, consult YUKEN INDIA LTD.

Flanges

Note: Please refer page no. 178 for flange details.

Spare Parts List

List of Seals

Sl. No.	Name of Part	Part Number	Qty.
1	O-Ring	PKH4-0208	1
2	O-Ring	PKH4-0209	1
3	O-Ring	PKH4-0210	1
4	Backup-Ring	PKH4-0185	1
5	Oil Seal (NOK)	34.9x57.15x8.3	1

Note: When ordering the seals, please specify the seal kit number KS-HPV3-10

Foot Mounting Parts

Sl. No.	Name of Part	Part Number	Qty.
1	Mounting Bracket	PK1-10182-3	1
2	Socket Head Cap Screw	M16 x 45Lg.	2
3	Spring Washer	WS-A-16	2

Note : When ordering the Foot Mounting Parts, please specify the Kit number HPV3-L-10.

HPV3M※-※-※-※※※-※-10

● Flange Mounting

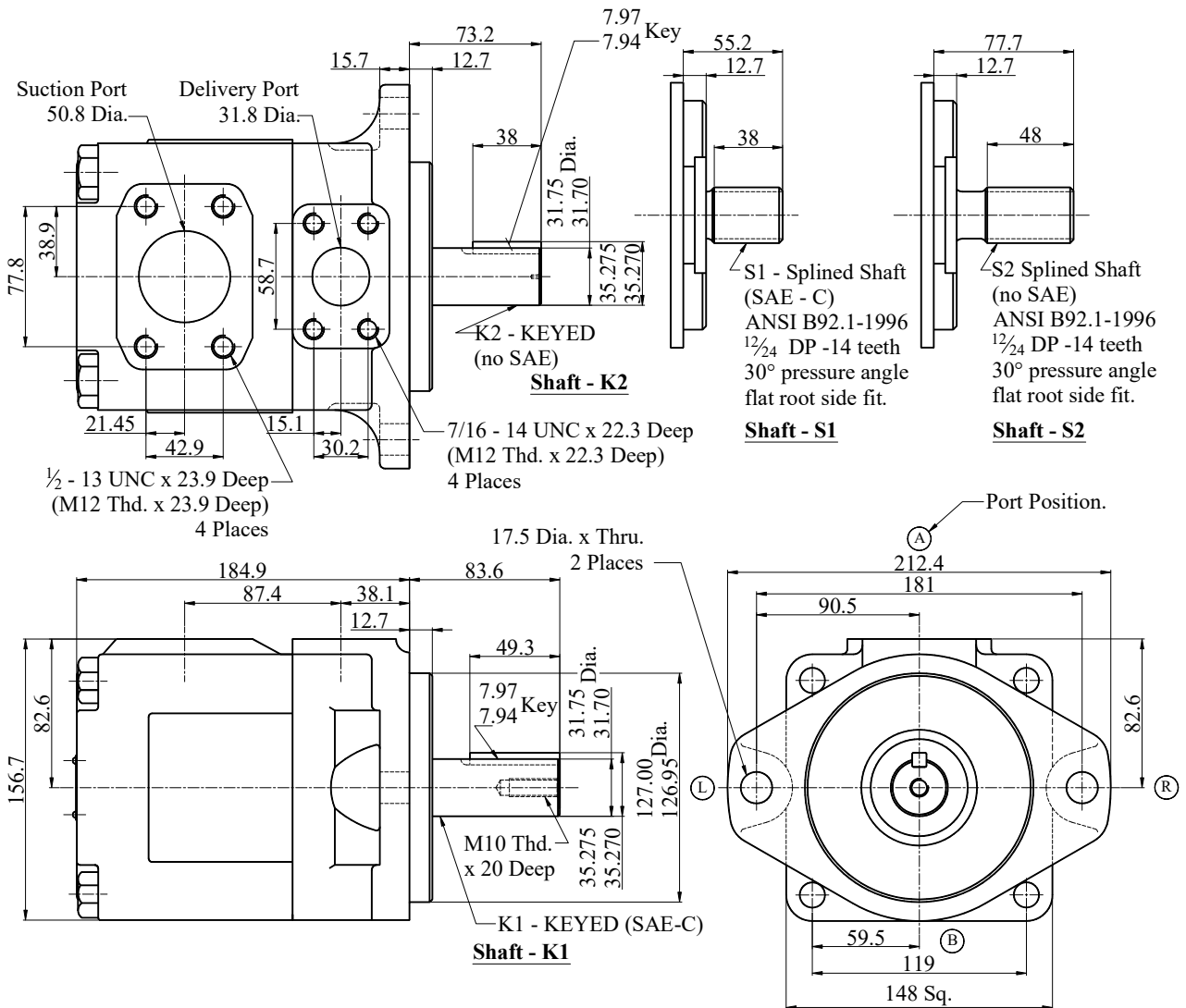

● Foot Mounting

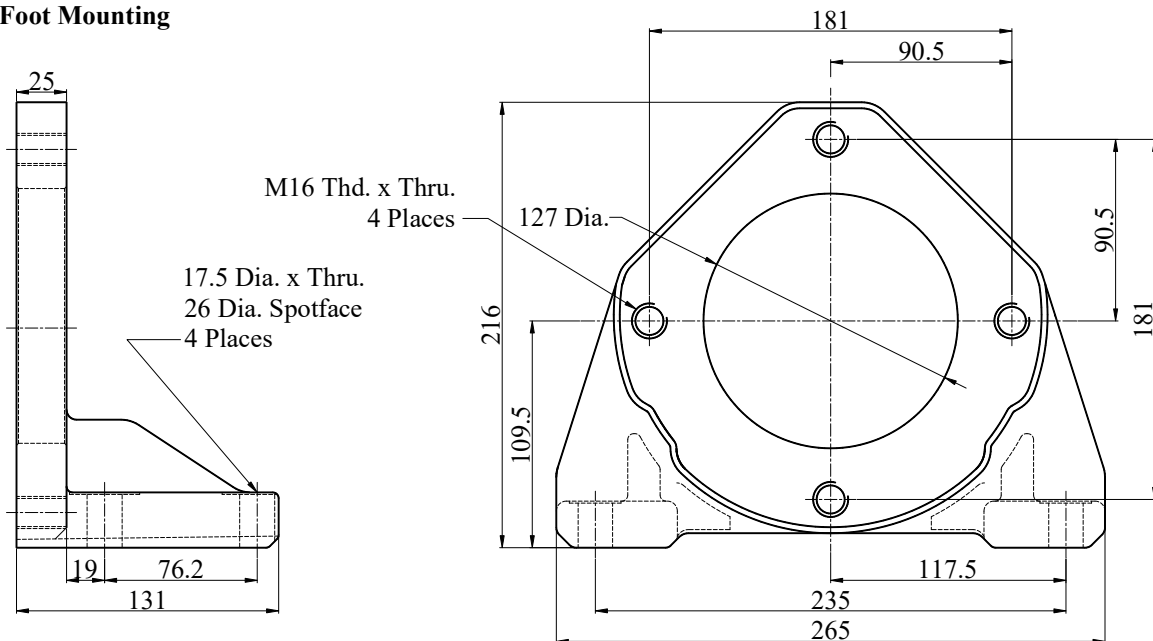

Typical Pump Characteristics Oil Viscosity 20 cSt [ISO VG 32, Temp 50⁰ C]

● HPV3M-14

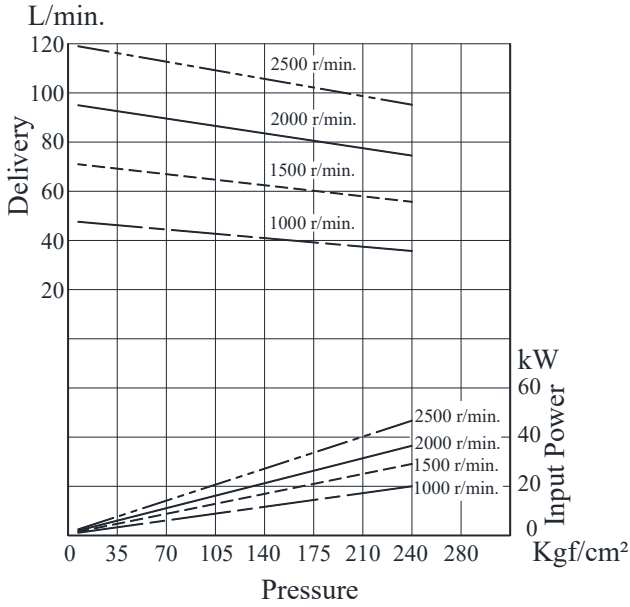

● HPV3M-17

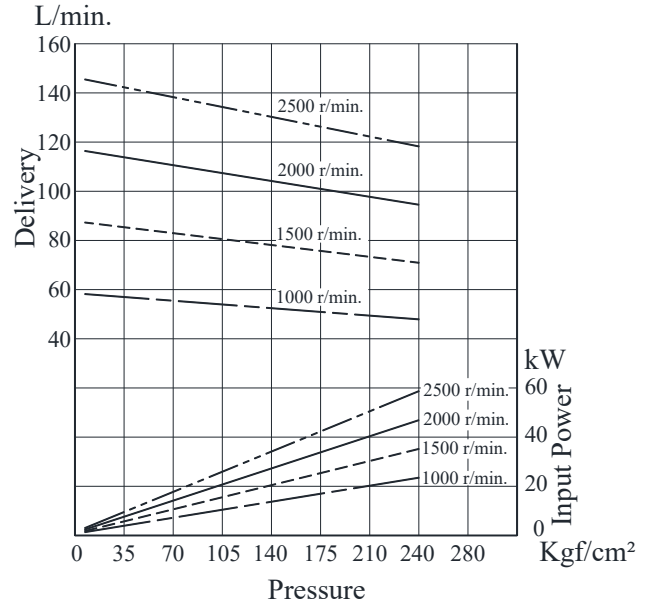

● HPV3M-20

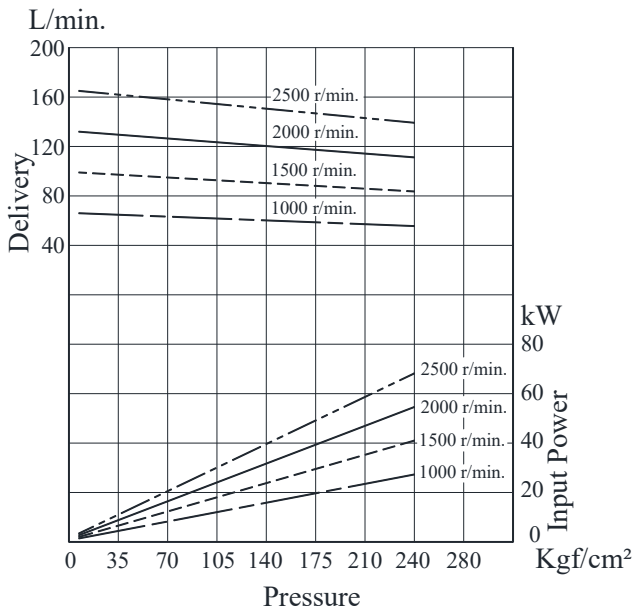

● HPV3M-24

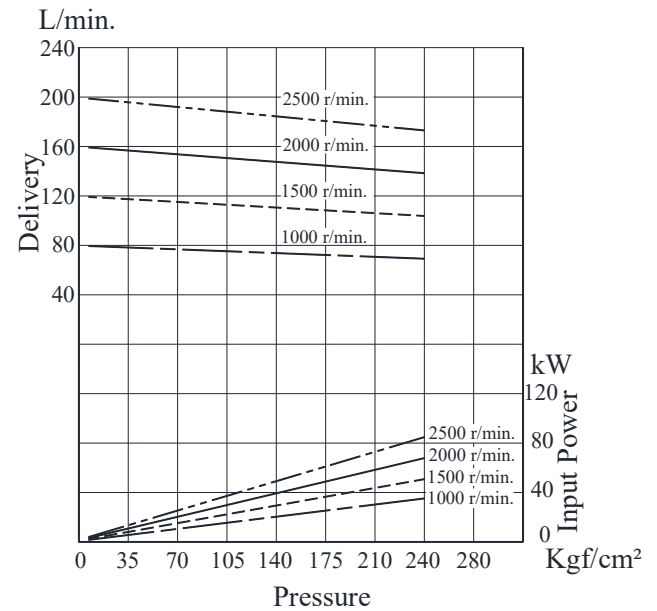

● HPV3M-28

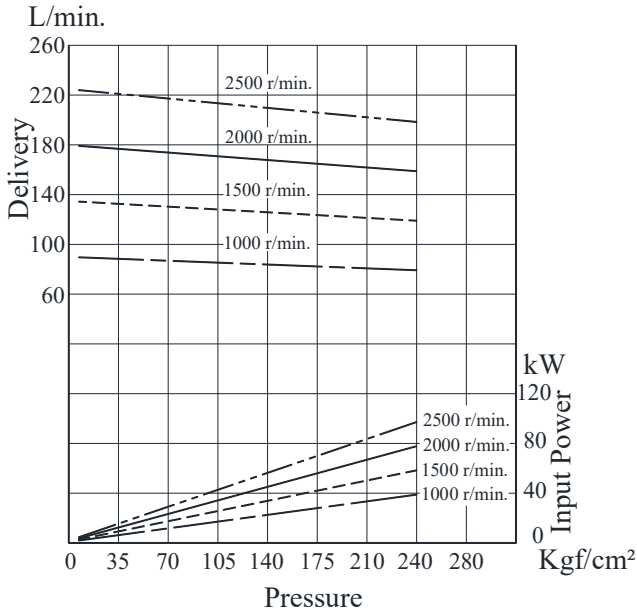

● HPV3M-31

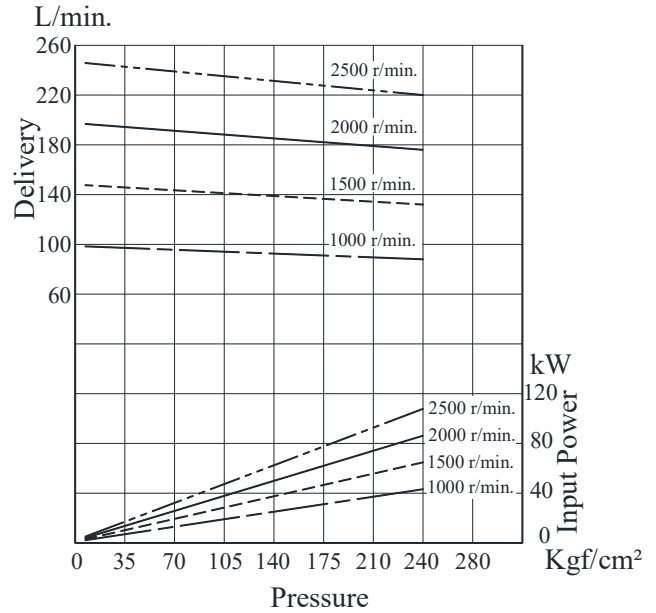

● HPV3M-35

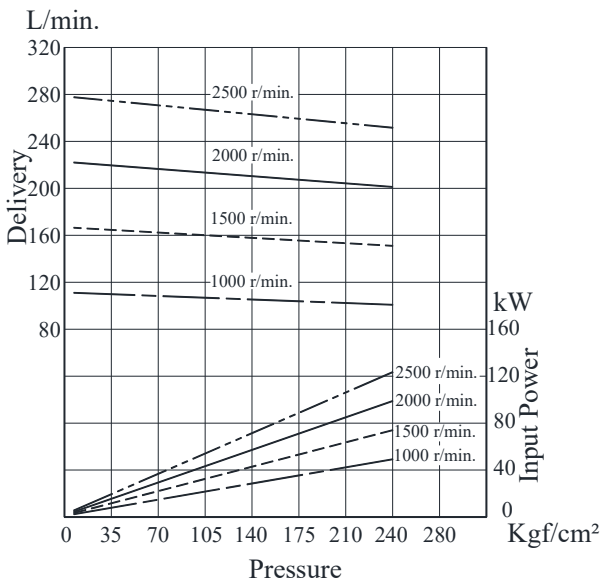

● HPV3M-38

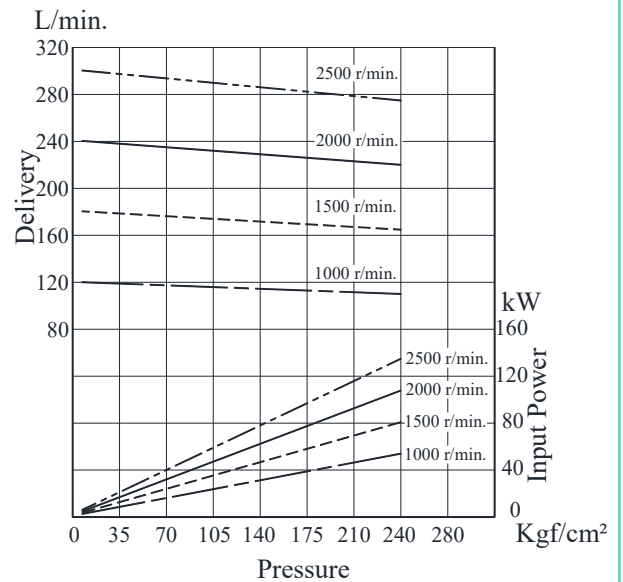

Typical Pump Characteristics Oil Viscosity 20 cSt [ISO VG 32, Temp 50⁰ C]

● HPV3M-42

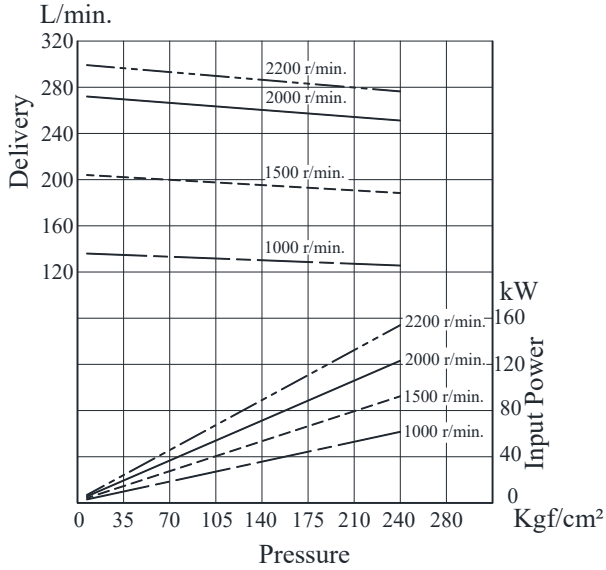

● HPV3M-45

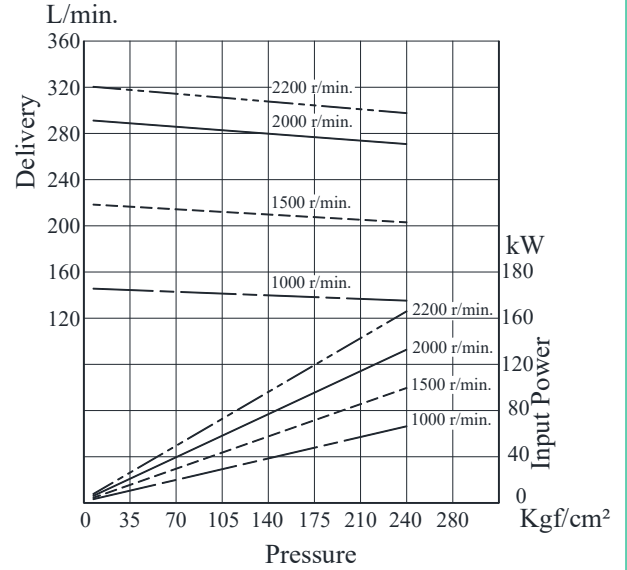

● HPV3M-50

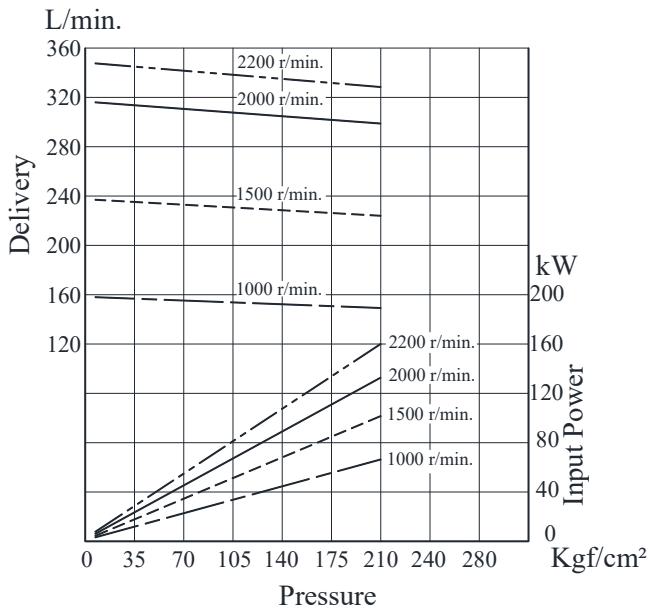

● HPV3M-61

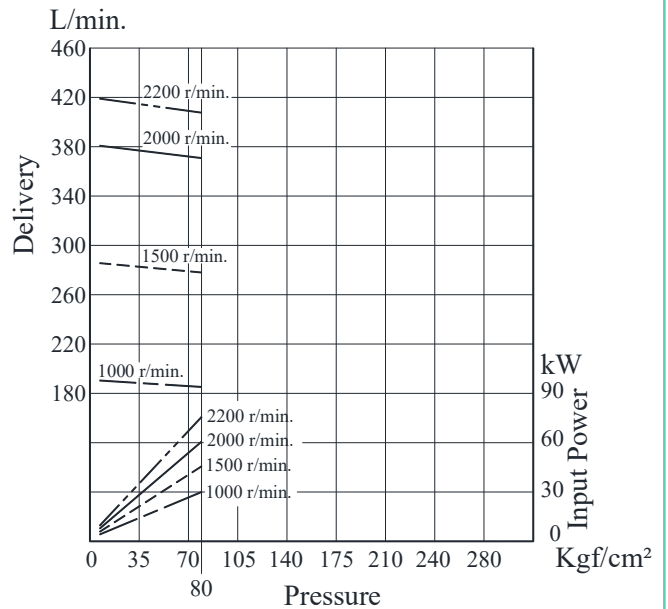

Hydraulic Fluids

- **Suction Pressure**
Suction line pressure limit -0.20Kgf/cm^2 to $+0.3\text{Kgf/cm}^2$
- **Cleanliness**
Contamination level should be within NAS class 9. The return line must have a line type filter of under $10\mu\text{m}$ or there should be an offline/independent filtration unit in the system.
- **Alignment of Shaft**
Employ a flexible coupling whenever possible & avoid stress from bending or thrust. Maximum permissible misalignment is less than $0.1\text{mm}(0.004\text{ inches})$ TIR & maximum permissible misangular is less than 0.2° .

Instructions

- **Precautions at starting**
At an initial operation or at an operation after a long rest, the pump may have difficulty in sucking up fluids. In such cases, an air bleed valve should be installed beforehand in the discharge side (Model No.ST1004-※-10※), or discharge air by slightly slackening the connection on the discharge side. At starting, operate the pump intermittently as far as possible with no load.
For fluid viscosity at starting, refer EIC-N-1001.
- **Other Precautions**
If a pump is used at speed below 1200 r/min., install the pump with the suction port upside so that the pump can suck up fluid easily at starting.

Cartridge Kit Model Number

Pump Model Numbers	Cartridge Kit Number #
HPV2M-05-※-R※※-※-20	CHPV2M-05-R-20
HPV2M-10-※-R※※-※-20	CHPV2M-10-R-20
HPV2M-14-※-R※※-※-20	CHPV2M-14-R-20
HPV2M-22-※-R※※-※-20	CHPV2M-22-R-20
HPV2M-31-※-R※※-※-20	CHPV2M-31-R-20
HPV3M-20-※-R※※-※-10	CHPV3M-20-R-10
HPV3M-35-※-R※※-※-10	CHPV3M-35-R-10
HPV3M-42-※-R※※-※-10	CHPV3M-42-R-10
HPV3M-61-※-R※※-※-10	CHPV3M-61-R-10

* For instructions regarding replacing cartridge kit, consult YUKEN INDIA LTD.

The above table does not include all combinations of cartridges available.
Only a few representative samples are shown.