

PV2R Series Single Vane Pumps

These pumps have been developed especially for low noise operation. PV2R Series provide a wide range of delivery volume [5.8-237.0 cm³/rev.] to comply with different applications, for instance Injection Moulding Machine.

The main internal parts of the pumps are built in the form of a cartridge kit, which minimizes down-time for replacement and maintenance.

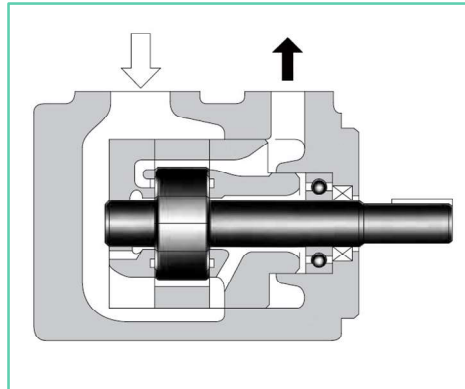

Graphic Symbol

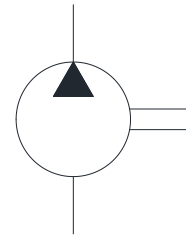

Specifications

Model Number	Geometric Displacement cm ³ /rev.	Max. Operating Pressure Kg/cm ²							Output Flow & Input Power	Shaft Speed Range r/min.	
		Petroleum Based Oils			Water Containing Fluids			Synthetic Fluids		Max.	Min.
		Specially *4 Specified	Antiwear Type	R & O Type	Antiwear Type *4 Water Glycols	Water Glycols	Water in Oil Emulsions	Phosphate Esters			
PV2R2 - 26	26.6	210	175	140	160	70	70	140	Refer Page 136 & 137	1800 (1200) ^{*2}	600 ^{*3}
PV2R2 - 33	33.3										
PV2R2 - 41	41.3										
PV2R2 - 47	47.2										
PV2R2 - 53	52.5										
PV2R2 - 59	58.2										
PV2R2 - 65	64.7	210	175	140	160	70	70	140	Refer Page 137, 138 & 139	1800 (1200) ^{*2}	600
PV2R3 - 52	52.2										
PV2R3 - 60	59.6										
PV2R3 - 66	66.3										
PV2R3 - 76	76.4										
PV2R3 - 94	93.6	160	160						1800 ^{*1} (1200) ^{*2}		
PV2R3 - 116	115.6										

*1 If PV2R3 - 116 is used at speed above 1700 r/min. the suction pressure is limited to 0 Kg/cm².

*2 If phosphate ester or water containing fluids are used, the maximum speed is limited to 1200 r/min.

*3 For starting at low speed, the maximum viscosity is limited. For details, see Hydraulic Fluids.

*4 For the brands of 'Antiwear type water glycol' and 'Specially specified' petroleum based oils see the 'Hydraulic Fluids' in EIC-N-1001.

Model Number Designation

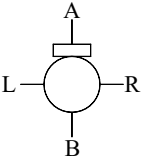
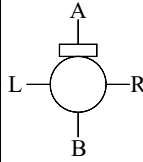
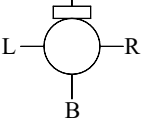
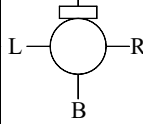
F-	PV2R1	-6	-L	-R	A	A	-40
Special Seals **	Series Number	Nominal Delivery	Type of Mounting	Shaft *	Discharge Port Position	Suction Port Position	Design Number
				Rotation	As Viewed from Shaft End		
F: Special Seals for Phosphate Ester type Fluids (Omit if not required)	PV2R2	26, 33, 41, 47, 53, 59, 65	L: Foot Mtg.	R: Clockwise (Normal)			40
	PV2R3	52, 60, 66, 76, 94, 116	F: Flange Mtg				30

* Supply of pumps with anti-clockwise rotation is possible. Consult Yuken for details.

* For instructions regarding changing the port positions, consult YUKEN INDIA LTD.

** Before ordering the Special Seals, consult YUKEN INDIA LTD.

Pipe Flange kits

Pipe flange Kits are available. When ordering, specify kits from the table below.

Pump Model Number	Name of Port	Pipe Flange Kit Numbers
		Threaded Connection
PV2R2	Suction	F5-10-A-1080
	Discharge	F5-06-A-1080
PV2R3	Suction	F5-16-A-1080
	Discharge	F5-10-A-1080

Note: Special seals (Viton Seals) are required when phosphate ester type fluids are used. (Prefix “F” before model code of pipe flange kit numbers when ordering).

Mass

Model Number	Mass Kg.	
	Flange Mtg.	Foot Mtg.
PV2R2	19.0	23.3
PV2R3	36.7	46.7

PV2R2-※-F-RAA-40

● **Flange Mounting**

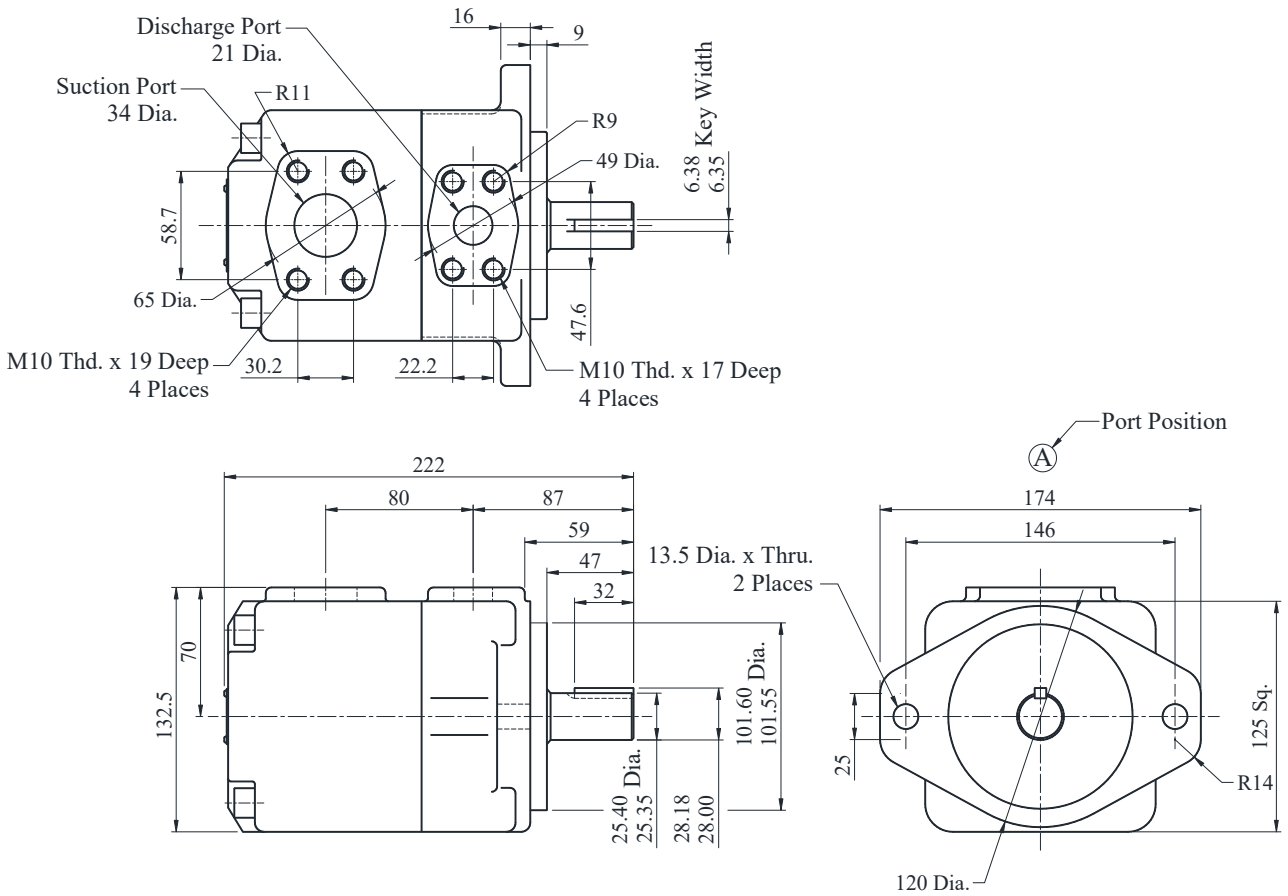

DIMENSIONS IN MILLIMETRES

PV2R2-※-L-RAA-40

● **Foot Mounting**

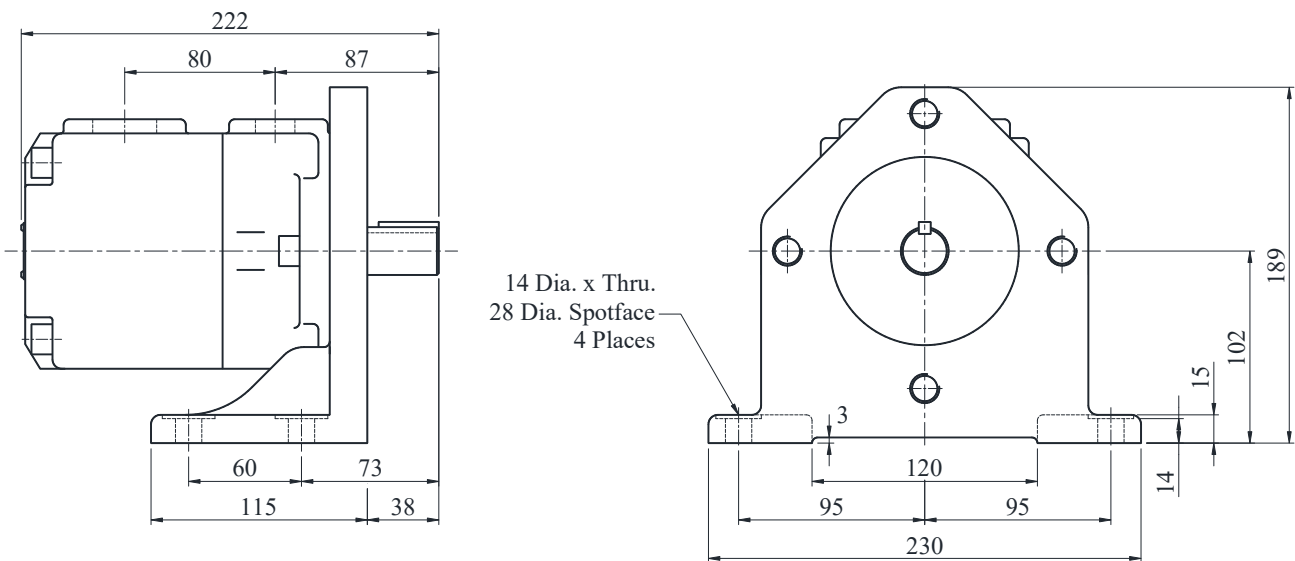

● For other dimensions, refer to “Flange Mtg”.

PV2R3-※-F-RAA-30

● **Flange Mounting**

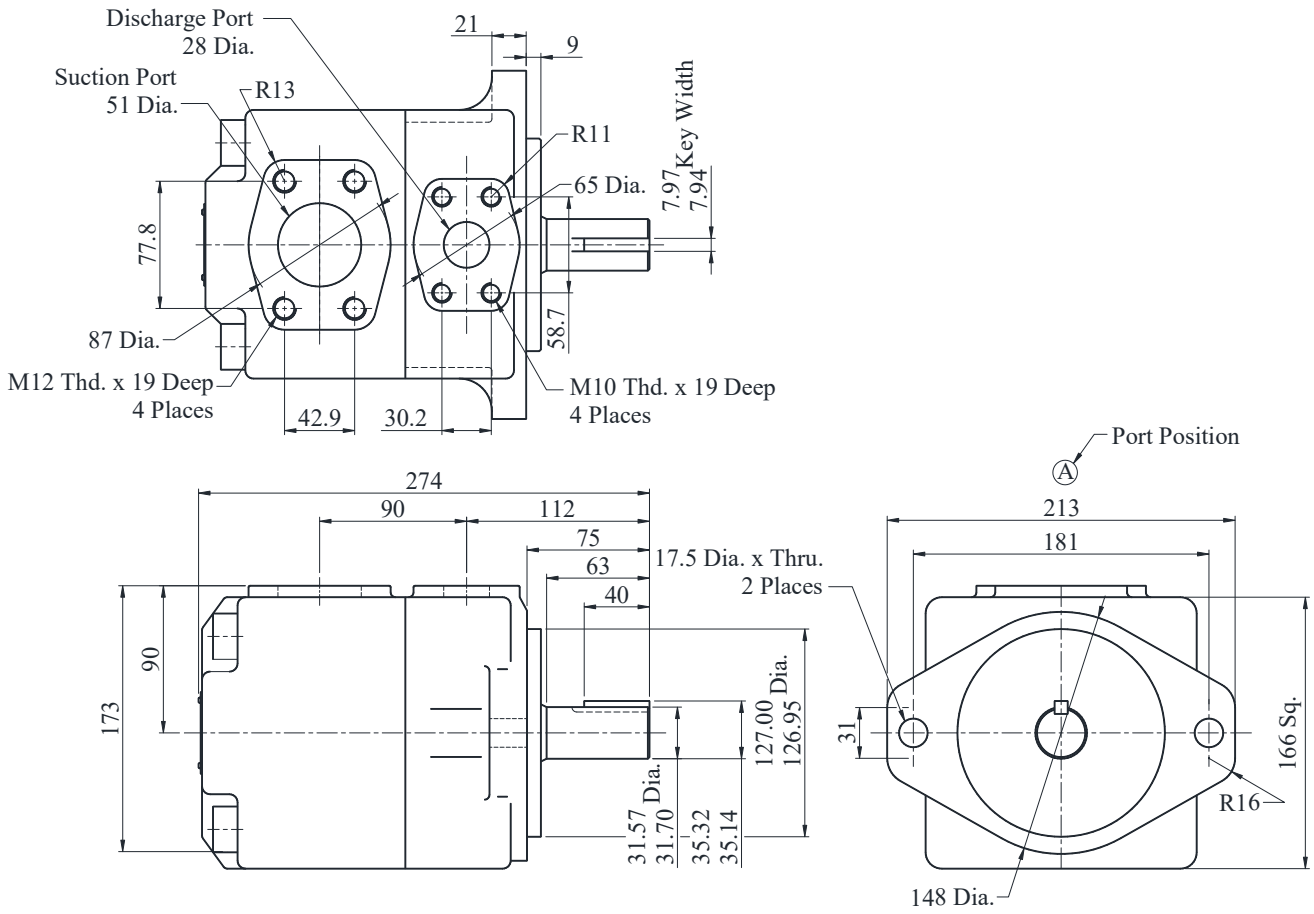

DIMENSIONS IN MILLIMETRES

PV2R3-※-L-RAA-30

● **Foot Mounting**

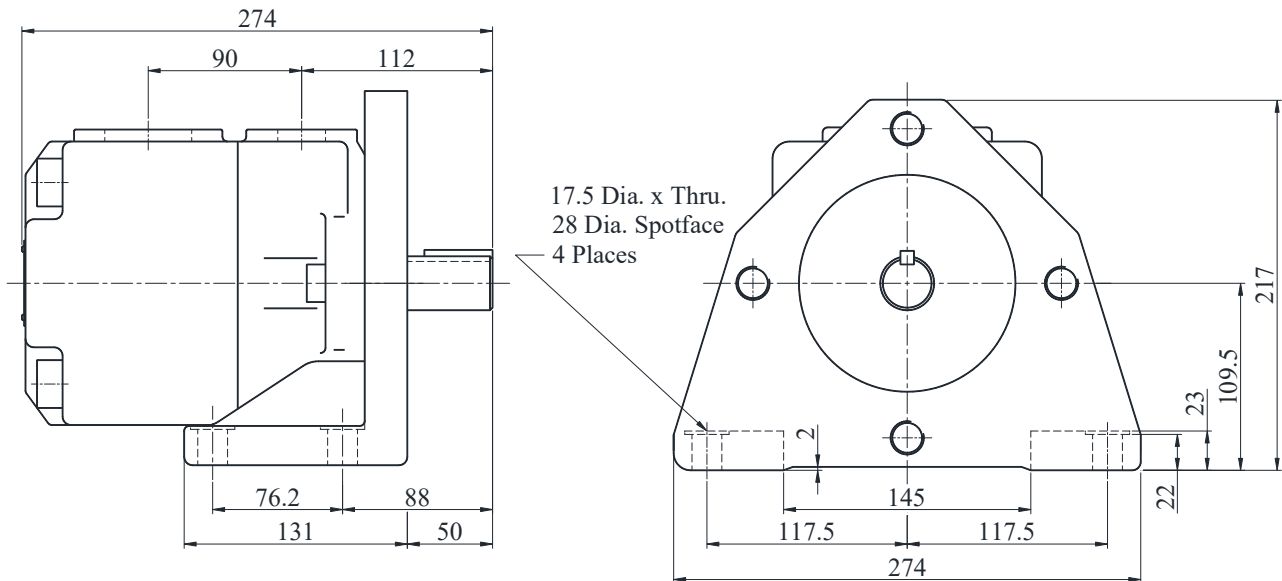

● For other dimensions, refer to “Flange Mtg”.

Noise Level

● **Measuring Conditions**

Fluid viscosity :20cSt

Measurement Point :One Meter horizontally away from head cover

Background Noise :40dB(A)

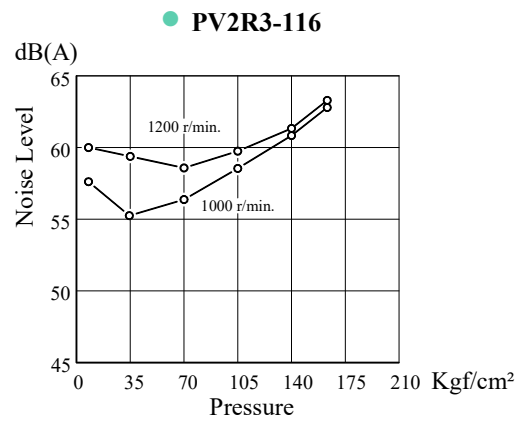
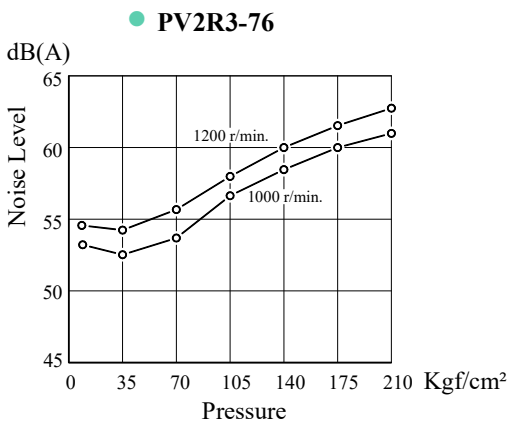
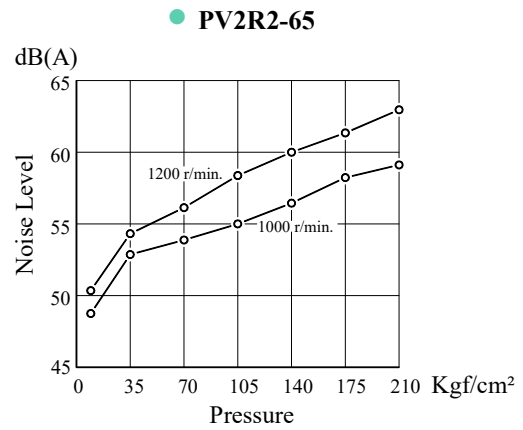
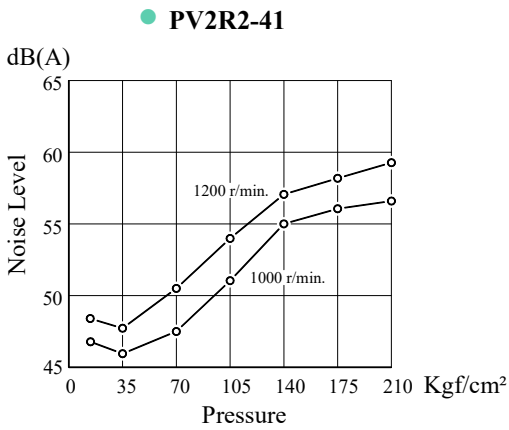
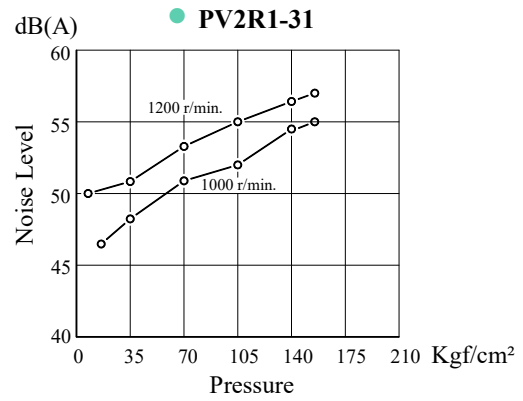
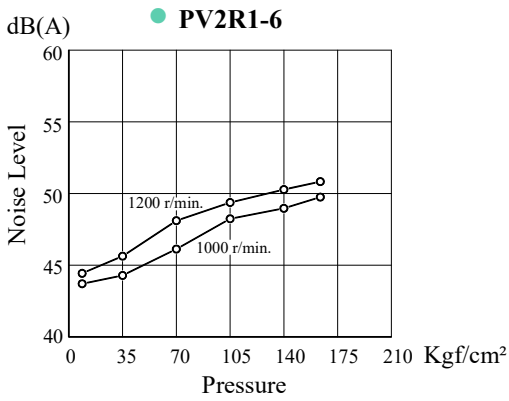

Typical Pump Characteristics Oil Viscosity 20 cSt [ISO VG 32, 50°C]

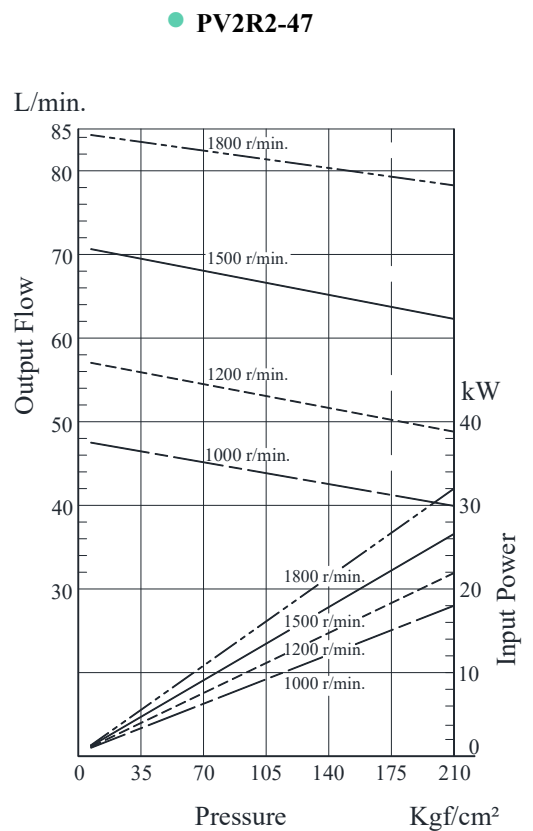
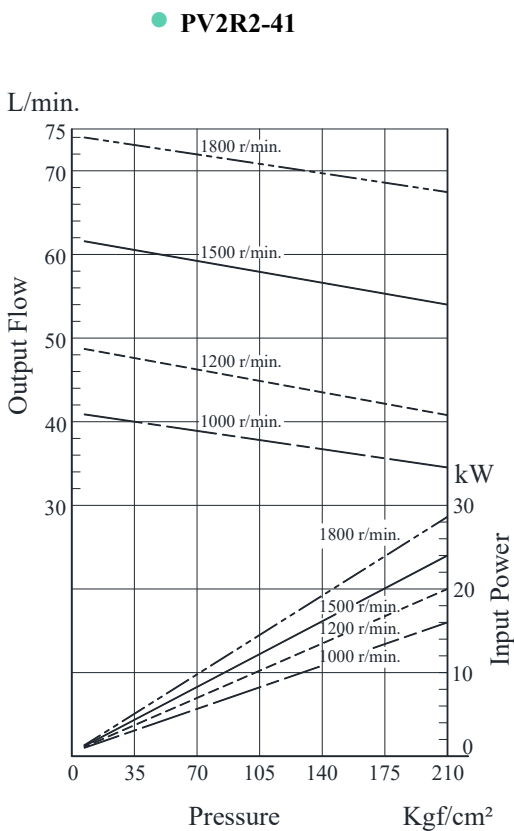
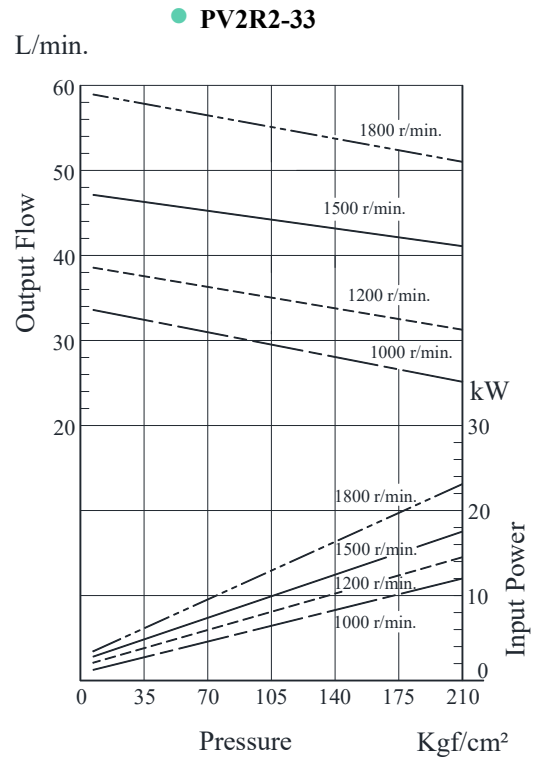
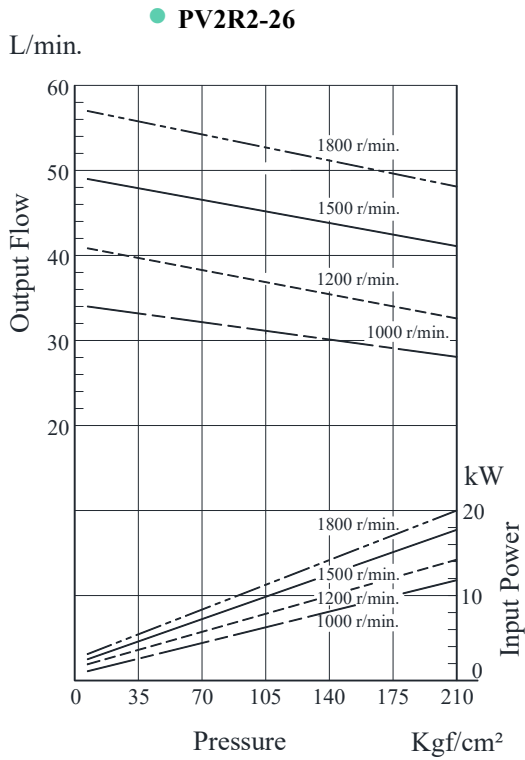

Typical Pump Characteristics Oil Viscosity 20 cSt [ISO VG 32, 50°C]

● PV2R2-53

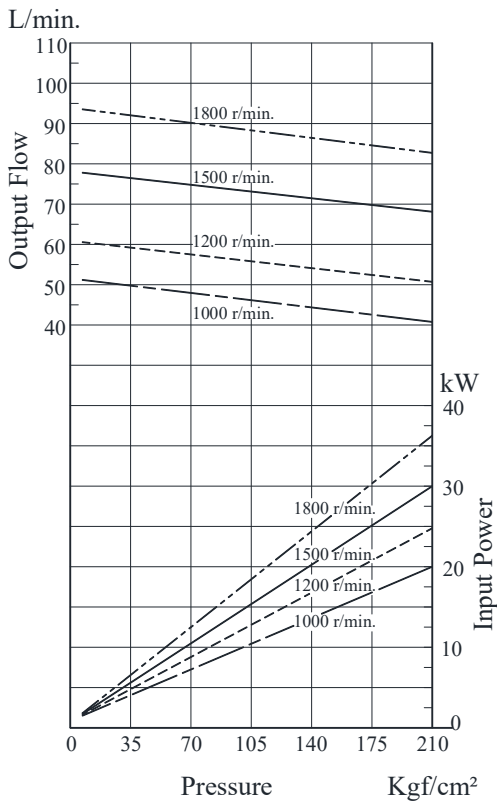

● PV2R2-59

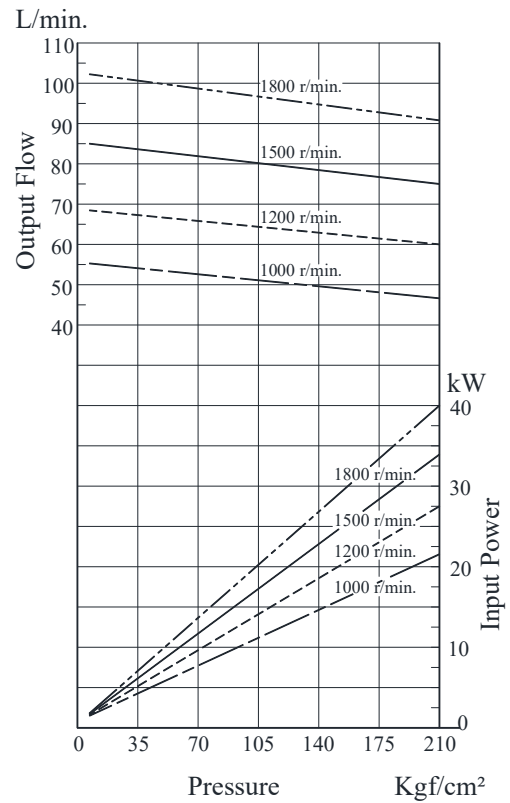

● PV2R2-65

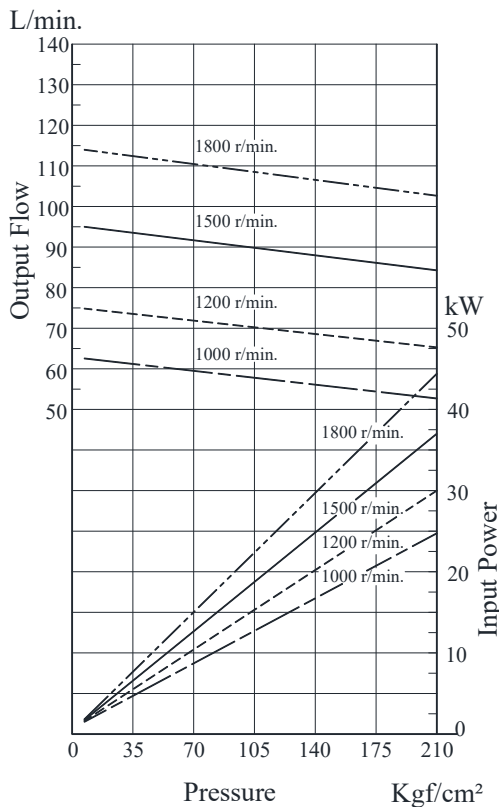

● PV2R3-52

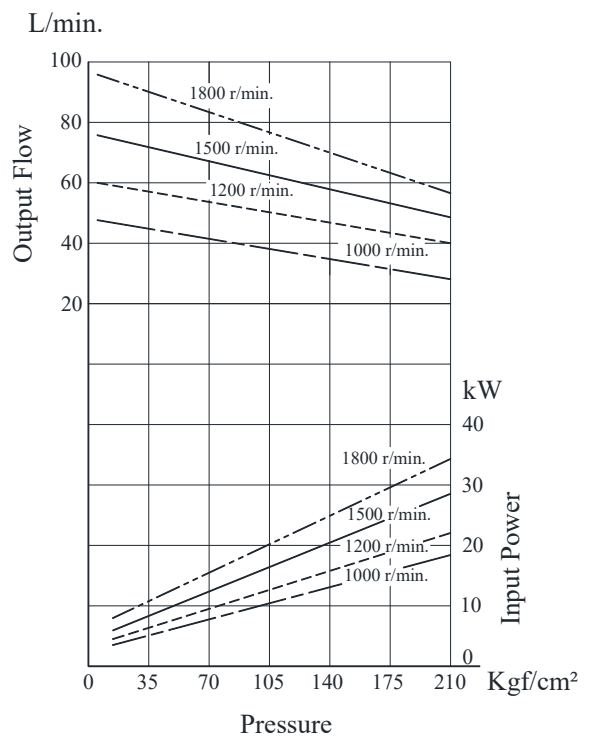

B
PV2R Series
Single Vane Pumps

Typical Pump Characteristics Oil Viscosity 20 cSt [ISO VG 32, 50°C]

● PV2R3-60

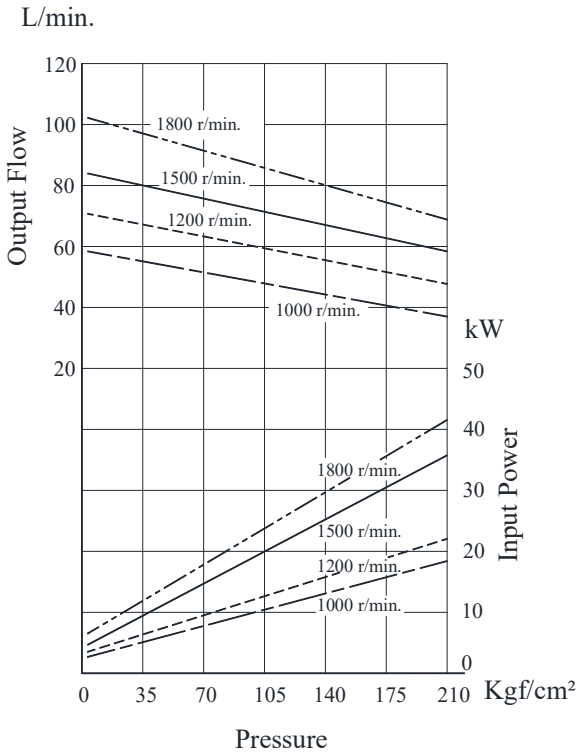

● PV2R3-66

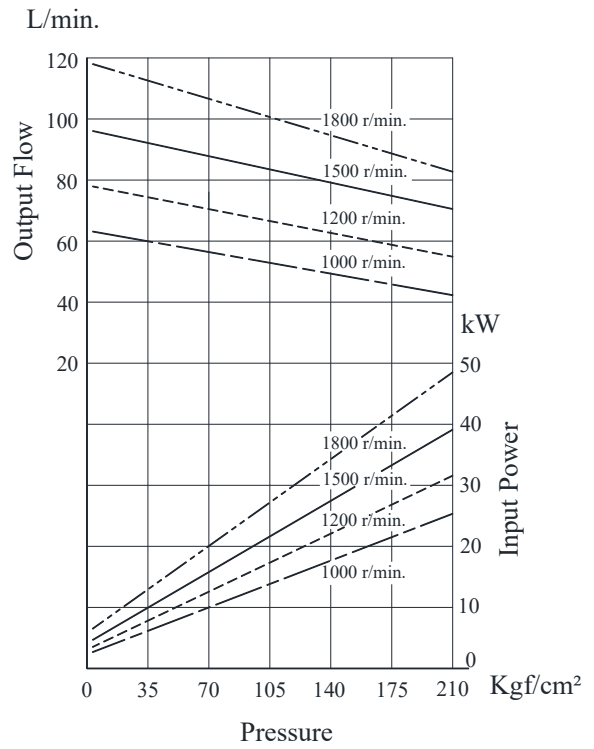

● PV2R3-76

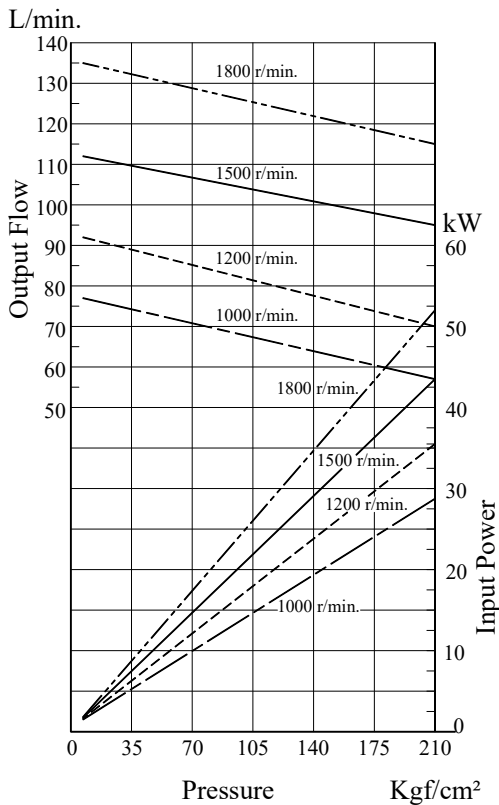

● PV2R3-94

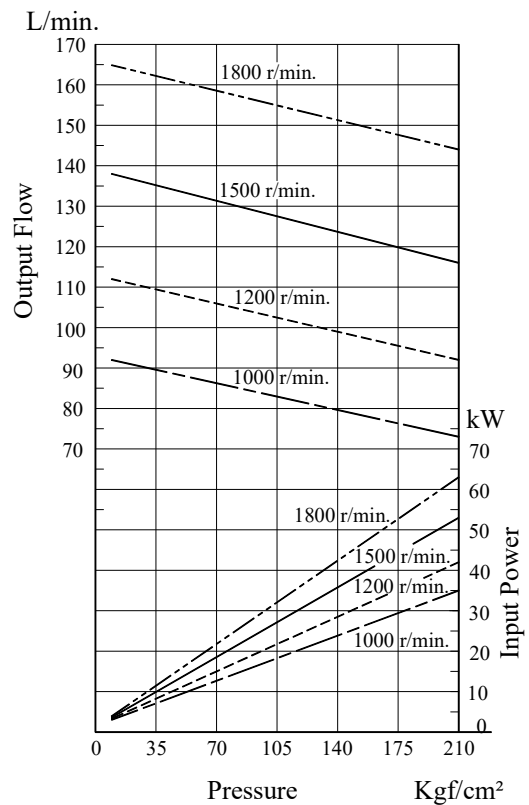

Typical Pump Characteristics Oil Viscosity 20 cSt [ISO VG 32, 50°C]

● PV2R3-116

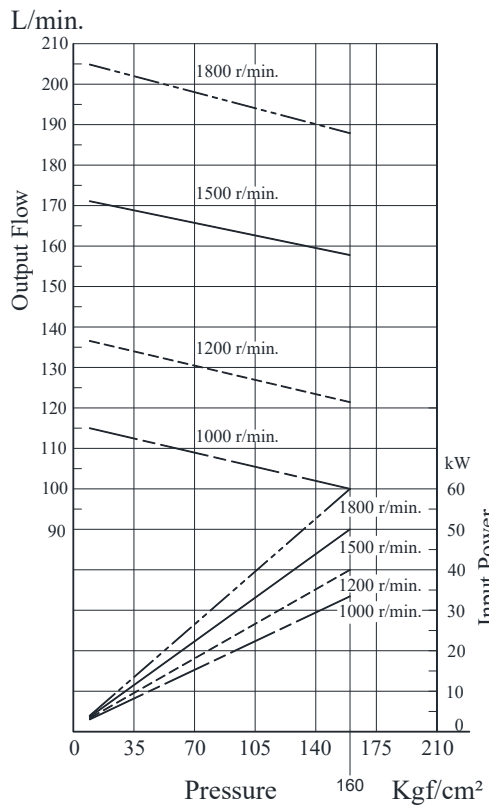

Cartridge Kit Model Number

Model Numbers	Cartridge Kit Number
PV2R2-26-※-R※※-40	CPV2R2-26-R-40
PV2R2-33-※-R※※-40	CPV2R2-33-R-40
PV2R2-41-※-R※※-40	CPV2R2-41-R-40
PV2R2-47-※-R※※-40	CPV2R2-47-R-40
PV2R2-53-※-R※※-40	CPV2R2-53-R-40
PV2R2-59-※-R※※-40	CPV2R2-59-R-40
PV2R2-65-※-R※※-40	CPV2R2-65-R-40
PV2R3-52-※-R※※-30	CPV2R3-52-R-30
PV2R3-60-※-R※※-30	CPV2R3-60-R-30
PV2R3-66-※-R※※-30	CPV2R3-66-R-30
PV2R3-76-※-R※※-30	CPV2R3-76-R-30
PV2R3-94-※-R※※-30	CPV2R3-94-R-30
PV2R3-116-※-R※※-30	CPV2R3-116-R-30

* For instructions regarding replacing cartridge kit, consult YUKEN INDIA LTD.

Spare Parts List

List of Seals

Sl. No.	Name of Parts	Part Numbers		Qty.
		PV2R2	PV2R3	
1	Oil Seal	ISD 30 42 8	ISD 35 55 11	1
2	O-Ring	SO-NB-G105	SO-NB-G135	1
3	O-Ring	SO-NB-G85	SO-NB-G115	1
4	O-Ring	SO-NB-P46	SO-NB-A231	1

List of Seal kits

Pump Model Numbers	Seal Kit Number
PV2R2-※-※-RAA-40	KS-PV2R2-40
PV2R3-※-※-RAA-31	KS-PV2R3-30