

SVP12 – Series Double Vane Pump

These double pumps consist of one SVP1 and one SVP2 series single pumps combined in tandem within a single housing and driven by a common shaft. Fluid delivered from the two separate ports can be either supplied to separate or common circuits.

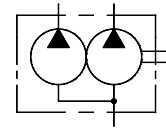

Graphic symbol



Specifications

Model Number	Small Vol. Pump Geometric Displacement cm ³ /rev.	Large Vol. Pump Geometric Displacement cm ³ /rev.	Max. Opr. Pressure Kg/cm ²	Output Flow & Input Power kW	Shaft Speed Range r/min.		Mass (Kg.)	
					Max.	Min.	Flange Mtg.	Foot Mtg.
SVP12	Refer Specification in Page 152	Refer Specification in Page 158	210	Refer Page 156, 157, 161, 162 & 163	1800*	600	18.75	22

* For speeds above 1500 r/min., consult factory for information.

Model Number Designation

F-	SVP12	-L	-F	-3	-11	-R	E	A	A	-10
Special Seals**	Series Number	Mounting	Type of Pipe Connection	Small Vol. Pump Nominal Delivery	Large Vol. Pump Nominal Delivery	Direction of Rotation	Small Vol. Pump Discharge Position	Large Vol. Pump Discharge Position	Suction Port Position	Design No.
				3	11		As viewed from shaft end			
F: For Phosphate Ester Type Fluids. (Omit if not required)	SVP12	L: Foot Mounting F: Flange Mounting	F: Flange Connection	5 7 8 10 13 14 26	17 22 25 30 33 38 43 47	R: Clockwise (Normal) L: Anticlockwise				10

* Design numbers subject to change from 10 to 19, but installation dimensions remain as shown.

* For instructions regarding changing the port positions, consult YUKEN INDIA LTD.

** Before ordering the Special Seals, consult YUKEN INDIA LTD.

Cartridge Kit Model Number

Large Volume Pump

CSVP12	-11	-R	-10
Model Number	Nominal Delivery	Shaft Rotation	Design No.
CSVP12	11	R: Clockwise (Normal)	10
	17		
	22		
	25		
	30	L: Counter- Clockwise	
	33		
	38		
	43		
	47		

Small Volume Pump

CSVP1	-3	-R	-10
Model Number	Nominal Delivery	Shaft Rotation	Design No.
CSVP12	3	R: Clockwise (Normal)	10
	5		
	7		
	8		
	10	L: Counter- Clockwise	
	13		
	14		
	26		

* For instructions regarding replacing cartridge kit, consult YUKEN INDIA LTD.

Flanges

Note: Please refer page no. 749 for flange details.

Spare Parts List

List of Seals

Sl. No.	Name of Part	Part Number	Qty.
1	O-Ring	SO-NB-G35	1
2	O-Ring	SO-NA-P41	1
3	O-Ring	SO-NB-G60	1
4	O-Ring	SO-NA-G80	1
5	O-Ring	SO-NB-G80	1
6	O-Ring	SO-NB-G95	1
7	Backup-Ring	SO-BB-P41	1
8	Backup-Ring	SO-BB-G80	1
9	Oil Seal	ISPD 25388	1

Note: When ordering the seals, please specify the seal kit number KS-SVP12-10.

SVP12-F-F-※-※-※※※※-10

● **Flange Mounting**

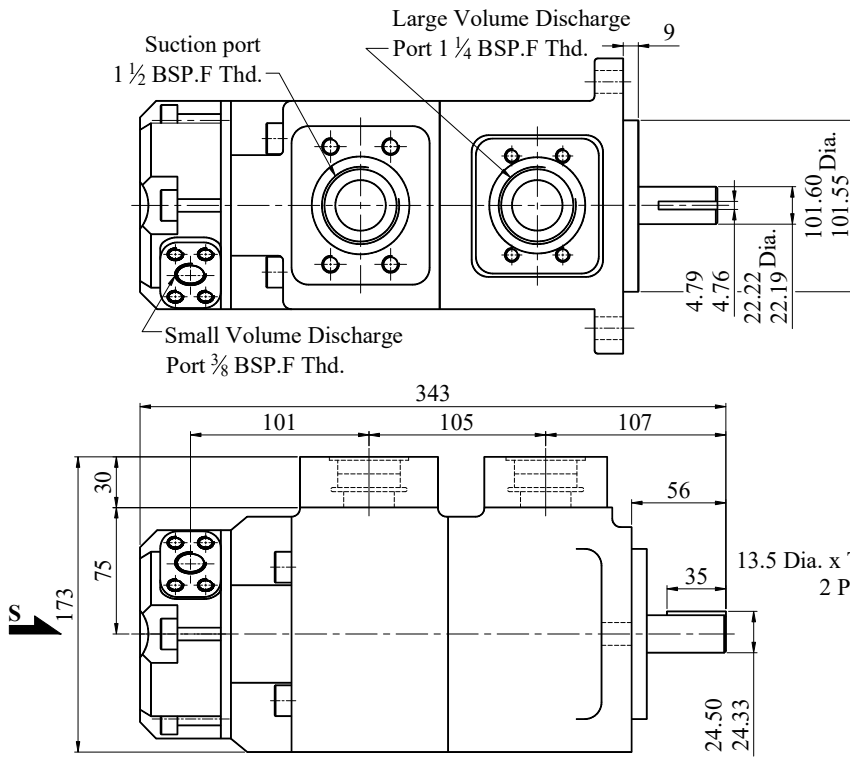

DIMENSIONS IN MILLIMETRES

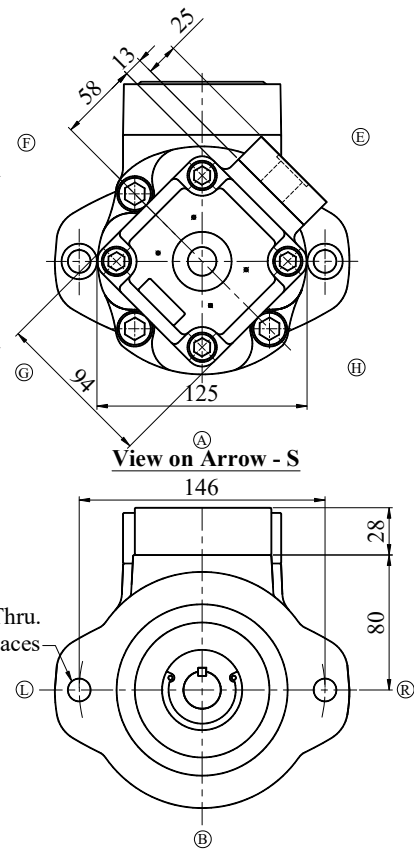

SVP12-L-F-※-※-※※※※-10

● **Foot Mounting**

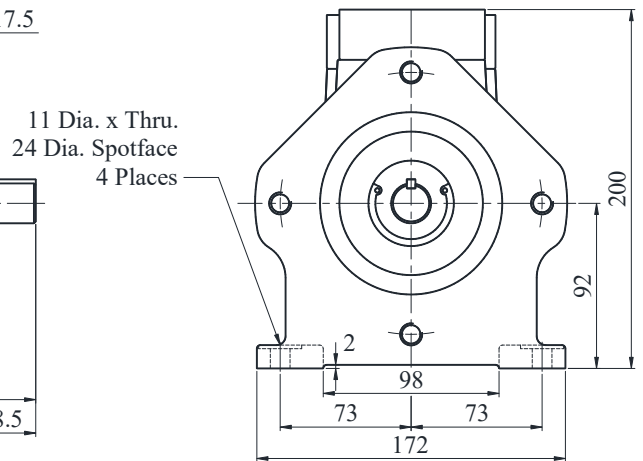
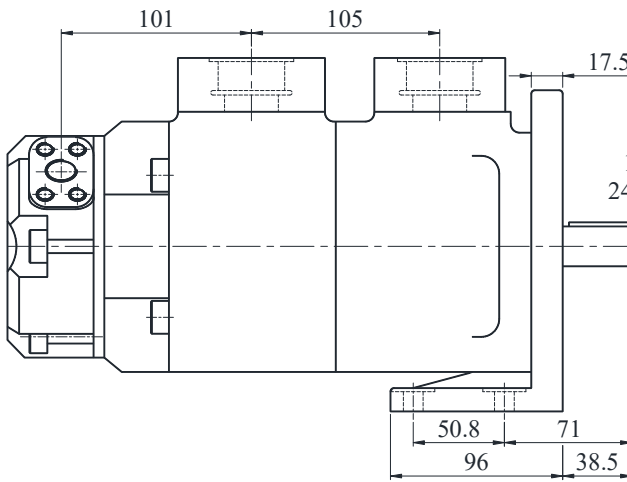

For Reference: Dimensions of Pipe Flange Mounting Surfaces

Small Volume Pump Discharge Port

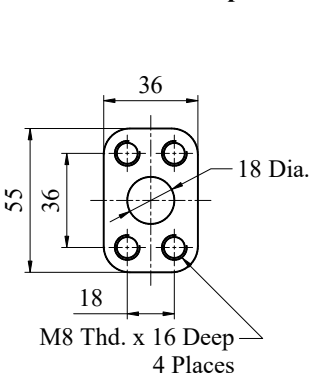

Suction Port

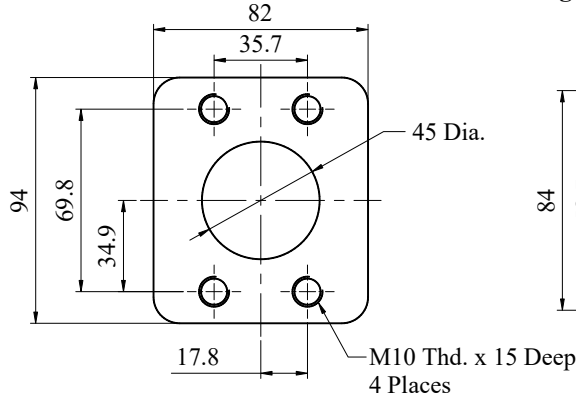

Large Volume Pump Discharge Port

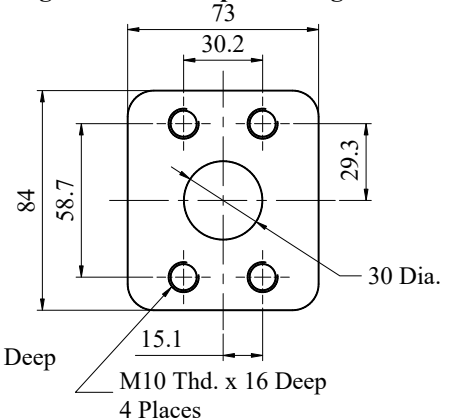

SVP23 – Series Double Vane Pump

These double pumps consist of one SVP2 and one SVP3 series single pumps combined in tandem within a single housing and driven by a common shaft. Fluid delivered from the two separate ports can be either supplied to separate or common circuits. These pumps are used in mobile application.



Graphic symbol

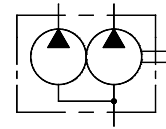

Specifications

Model Number	Small Vol. Pump Geometric Displacement cm ³ /rev.	Large Vol. Pump Geometric Displacement cm ³ /rev.	Max. Opr. Pressure Kg/cm ²	Output Flow & Input Power kW	Shaft Speed Range r/min.		Mass (Kg.)	
					Max.	Min.	Flange Mtg.	Foot Mtg.
SVP23	Refer Specification in Page 158	Refer Specification in Page 164	210	Refer Page 161, 162, 163, 166 & 167	1800*	600	43	49.5

* For speeds above 1500 r/min., consult factory for information.

Model Number Designation

F-	SVP23	-L	-F	-11	-50	-R	E	A	A	-10
Special Seals **	Series Number	Mounting	Type of Pipe Connection	Small Vol. Pump Nominal Delivery	Large Vol. Pump Nominal Delivery	Direction of Rotation	Small Vol. Pump Discharge Position	Large Vol. Pump Discharge Position	Suction Port Position	Design *
				11	50		As viewed from shaft end			
F: For Phosphate Ester Type Fluids. (Omit if not required)	SVP23	L: Foot Mounting F: Flange Mounting	F: Flange Connection	17 22 25 30 33 38 43	50 58 75 92 117 142	R: Clockwise (Normal) L: Anticlockwise				10

* Design numbers subject to change from 10 to 19, but installation dimensions remain as shown.

* For instructions regarding changing the port positions, consult YUKEN INDIA LTD.

** Before ordering the Special Seals, consult YUKEN INDIA LTD.

Cartridge Kit Model Number

● **Large Volume Pump**

CSVP23	-50	-R	-10
Model Number	Nominal Delivery	Shaft Rotation	Design No.
CSVP23	50	R: Clockwise (Normal)	10
	58		
	75		
	92	L: Counter- Clockwise	
	117		
	142		

● **Small Volume Pump**

CSVP23	-11	-R	-10
Model Number	Nominal Delivery	Shaft Rotation	Design No.
CSVP23	11	R: Clockwise (Normal)	10
	17		
	22		
	25		
	30		
	33	L: Counter- Clockwise	
	38		
	43		

* For instructions regarding replacing cartridge kit, consult YUKEN INDIA LTD.

Cartridge Kit Model Number

Pump Model Numbers	Cartridge Kit Number #	
	Small Volume Pump	Large Volume Pump
SVP12-※-F-5*-REAA-10	CSVP1-5-R-10	CSVP12-*-R-10
SVP12-※-F-8*-REAA-10	CSVP1-8-R-10	
SVP12-※-F-10*-REAA-10	CSVP1-10-R-10	
SVP12-※-F-14*-REAA-10	CSVP1-14-R-10	
SVP12-※-F-26*-REAA-10	CSVP1-26-R-10	
SVP23-※-F-17*-REAA-10	CSVP23-17-L-10	CSVP23-*-R-10
SVP23-※-F-25*-REAA-10	CSVP23-25-L-10	
SVP23-※-F-33*-REAA-10	CSVP23-33-L-10	
SVP23-※-F-38*-REAA-10	CSVP23-38-L-10	
SVP23-※-F-43*-REAA-10	CSVP23-43-L-10	

* For instructions regarding replacing cartridge kit, consult YUKEN INDIA LTD.

The above table does not include all combinations of cartridges available.

Only a few representative samples are shown.

Flanges

Note: Please refer page no. 749 for flange details.

Spare Parts List

● **List of Seals**

Sl. No.	Name of Part	Part Number	Qty.
1	O-Ring	SO-NB-G85	1
2	O-Ring	SO-NA-P41	1
3	O-Ring	ARP 568- 231	1
4	O-Ring	SO-NA-G80	1
5	O-Ring	SO-NB-G125	1
6	Backup-Ring	SO-BB-G120	1
7	Backup-Ring	JIS W 1516-G9	1
8	Backup-Ring	SO-BB-P41	1
9	Backup-Ring	SO-BB-G80	1
10	O-Ring	SO-NA-G120Y	1
11	Oil Seal	38 55 8	1

Sl. No.	Name of Part	Part Number	Qty.
10	Backup-Ring	SO-BB-G120	1
11	Backup-Ring	JIS W 1516-G9	1
12	Backup-Ring	SO-BB-P41	1
13	Backup-Ring	SO-BB-G80	1
14	Oil Seal	38 55 8	1

Note: When ordering the seals, please specify the seal kit number KS-SVP23-10.

SVP23-F-F-※-※-※※※※-10

● **Flange Mounting**

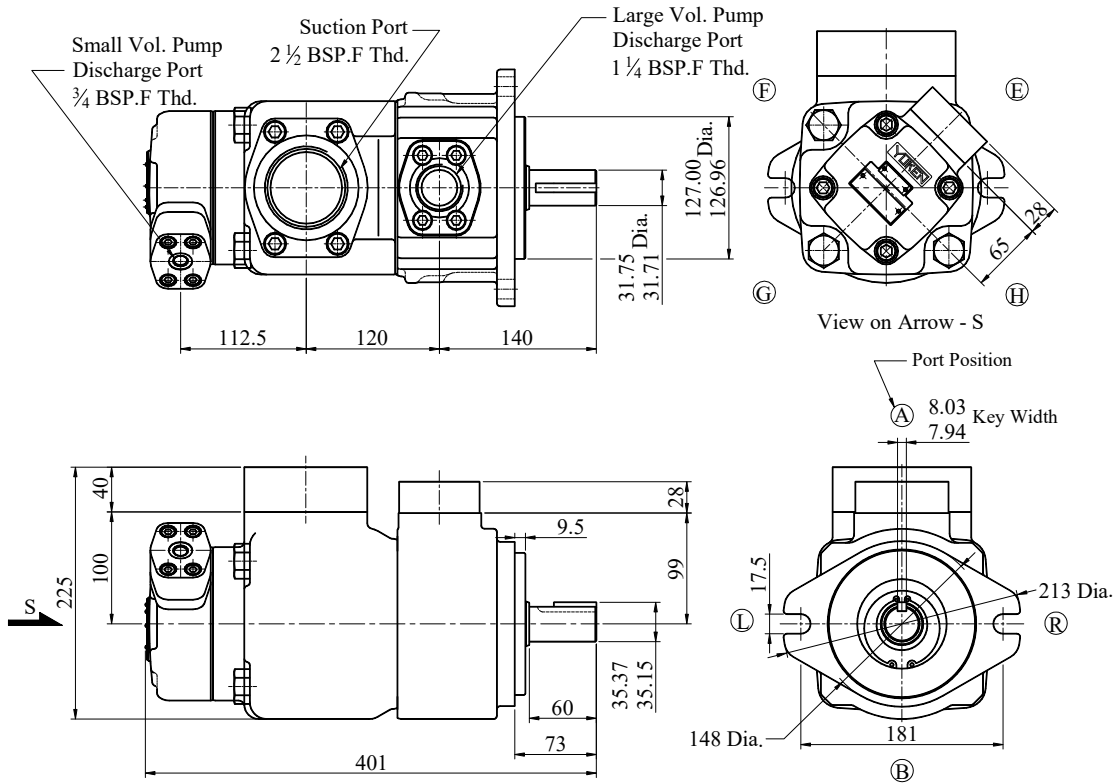

SVP23-L-F-※-※-※※※※-10

● **Foot Mounting**

DIMENSIONS IN MILLIMETRES

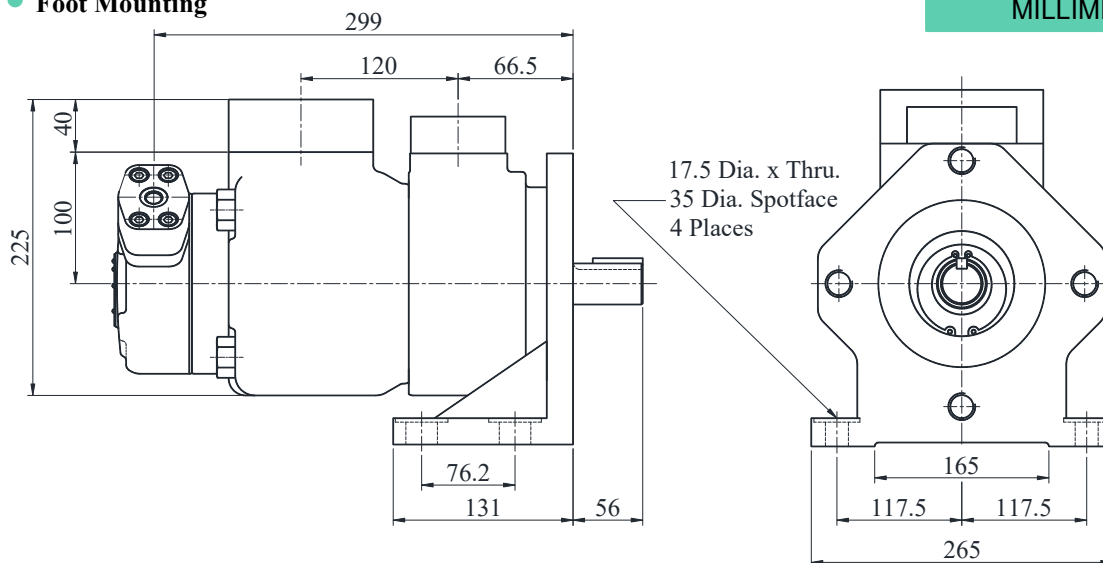

For Reference: Dimensions of Pipe Flange Mounting Surfaces

Small Volume Pump Discharge Port

Suction Port

Large Volume Pump Discharge Port

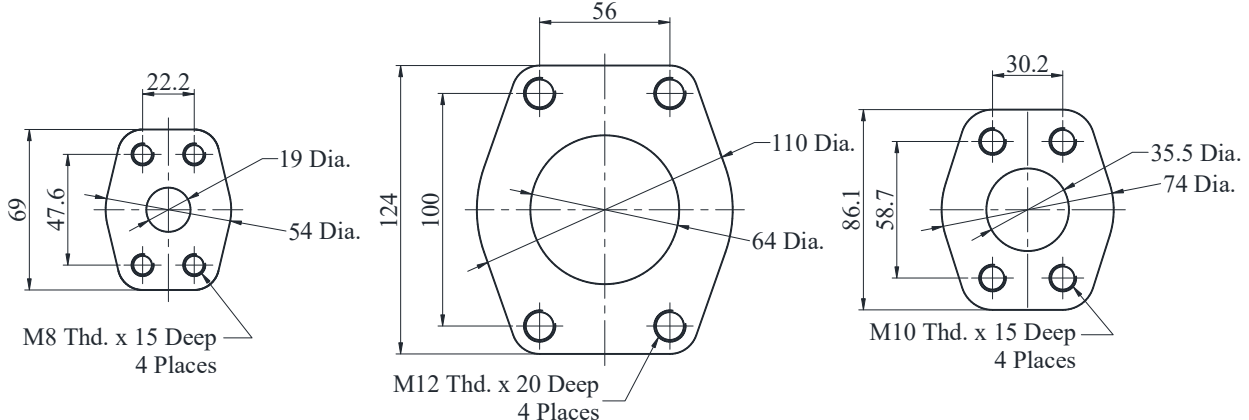

SVP Series Double Vane Pump