

### SVP1 – Series Single Vane Pump

These pumps work as a source of hydraulic power especially for low noise operation. They combine stable performance and robust construction with range of delivery rates.

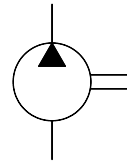

Graphic Symbol



### Specifications

Model Number	Geometric Displacement cm <sup>3</sup> /rev.	Max. Opr. Pressure Kg/cm <sup>2</sup>	Output Flow & Input Power kW	Shaft Speed Range r/min.		Mass Kg.	
				Max.	Min.	Flange Mounting	Foot Mounting
SVP1※-3	3.6	125	Refer Page 156 & 157	1800*	750	6.2	7
SVP1※-5	5.4	210					
SVP1※-7	7.8						
SVP1※-8	8.7						
SVP1※-10	11.6						
SVP1※-13	13.8						
SVP1※-14	14.3						
SVP1※-26	25.8						

\* For speeds above 1500 r/min., consult factory for information.

### Model Number Designation

F-	SVP1	T	-3	-L	-R	A	A	-10
Special Seals **	Series Number	Type of Connection	Nominal Delivery	Type of Mounting	Direction of Rotation	Discharge Port Position	Suction Port Position	Design Number *
					As Viewed From Shaft End			
<b>F:</b> For Phosphate Ester type Fluids. (Omit if not required)	<b>SVP1</b>	<b>T:</b> Threaded Connection	<b>3</b> <b>5</b> <b>7</b> <b>8</b> <b>10</b> <b>13</b> <b>14</b> <b>26</b>	<b>L:</b> Foot Type  <b>F:</b> Flange Type	<b>R:</b> Clockwise (Normal)  <b>L:</b> Counter-clockwise			<b>10</b>

\* Design numbers subject to change from 10 to 19, but installation dimensions remain as shown.

\* For instructions regarding changing the port positions, consult YUKEN INDIA LTD.

\*\* Before ordering the Special Seals, consult YUKEN INDIA LTD.

## ■ Cartridge Kit Model Number

CSVP1T	-3	-R	-10
Model Number	Nominal Delivery	Shaft Rotation	Design No.
CSVP1T	3	R: Clockwise (Normal)	10
	5		
	7		
	8		
	10	L: Counter- Clockwise	
	13		
	14		
	26		

\* For instructions regarding replacing cartridge kit, consult YUKEN INDIA LTD.

## ■ Spare Parts List

### ● List of Seals

Sl. No.	Name of Part	Part Number	Qty.
1.	O-Ring	SO-NB-G80	1
2.	O-Ring	SO-NB-G60	1
3.	O-Ring	SO-NB-G35	1
4.	Oil Seal	ISD 20307	1

Note: When ordering the seals, please specify the seal kit number KS-SVP1-10.

SVP1T-※ -F-※※ -10

DIMENSIONS IN MILLIMETRES

● Flange Mounting

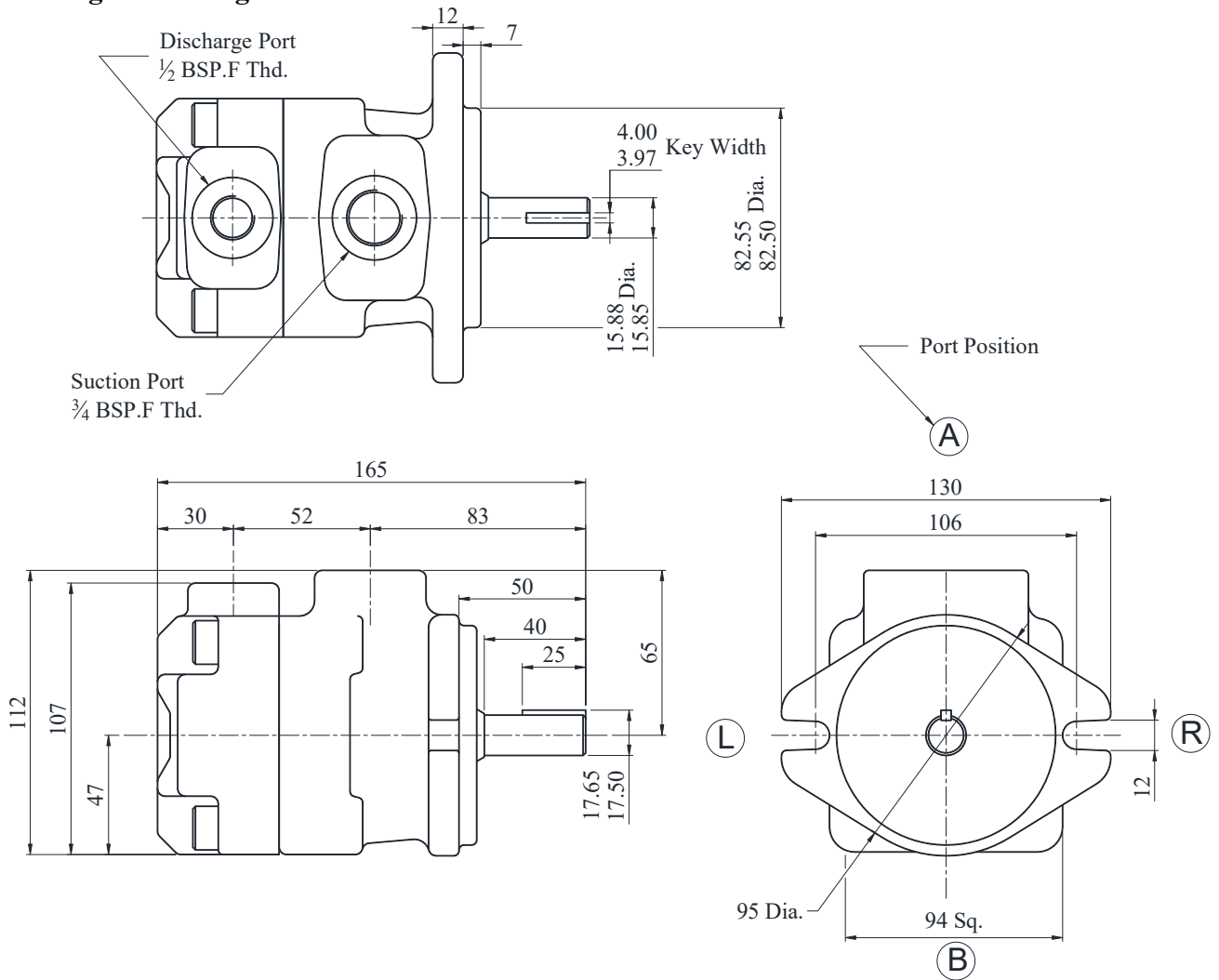

SVP1T-※ -L-※※ -10

● Foot Mounting

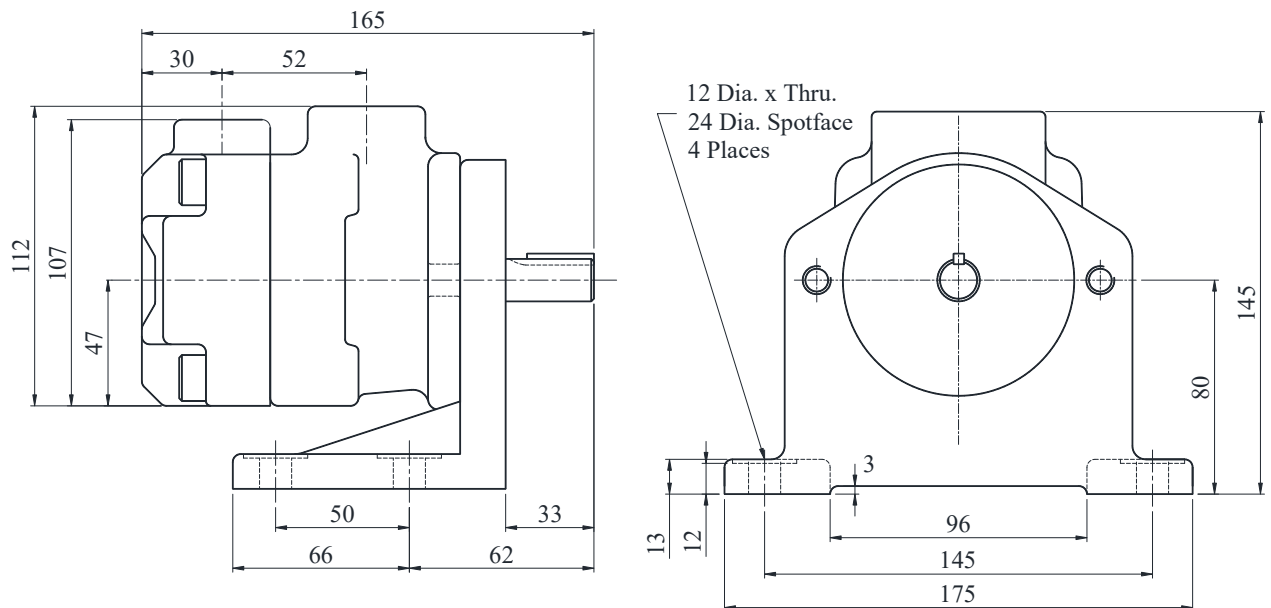

For further dimensions refer Flange Mounting.

SVP1T-26-※-F-※※ -10

DIMENSIONS IN MILLIMETRES

● Flange Mounting

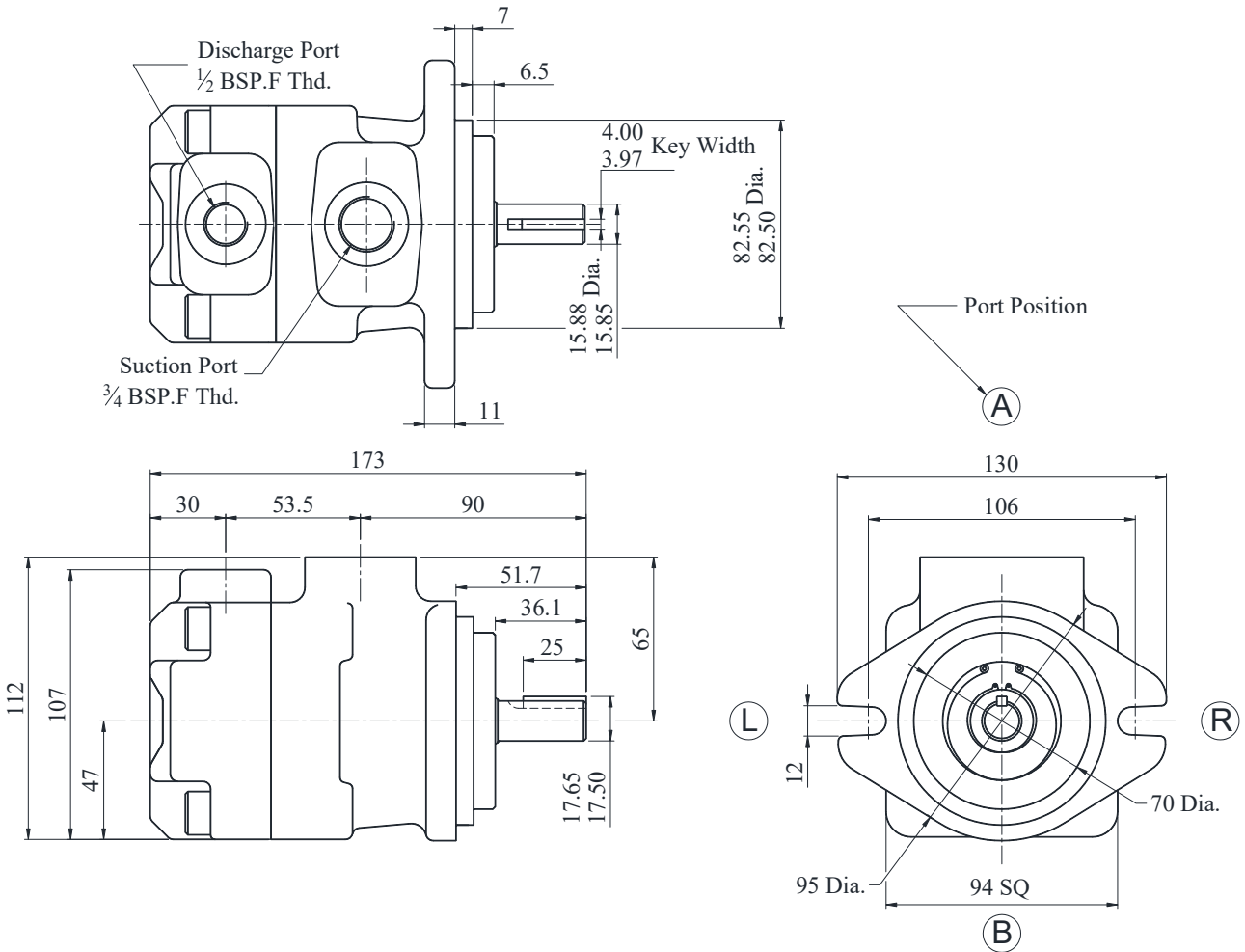

SVP1T-26-※-L-※※ -10

● Foot Mounting

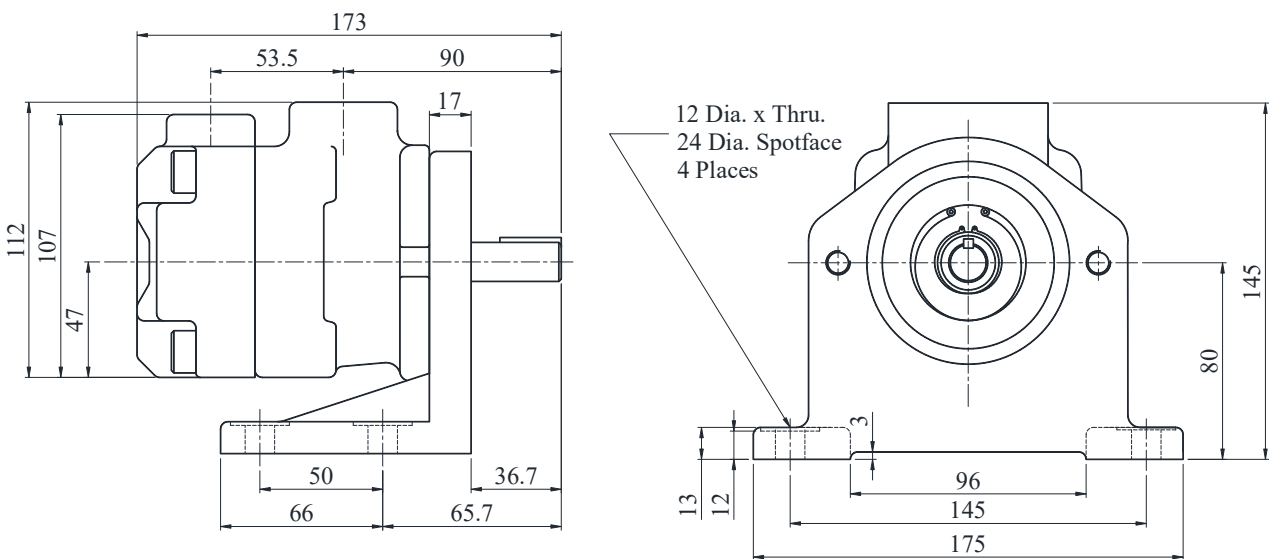

For further dimensions refer Flange Mounting.

Typical Pump Characteristics Oil Viscosity 20 cSt [VG 32, Temp 50<sup>0</sup>C]

● SVP1 – 3

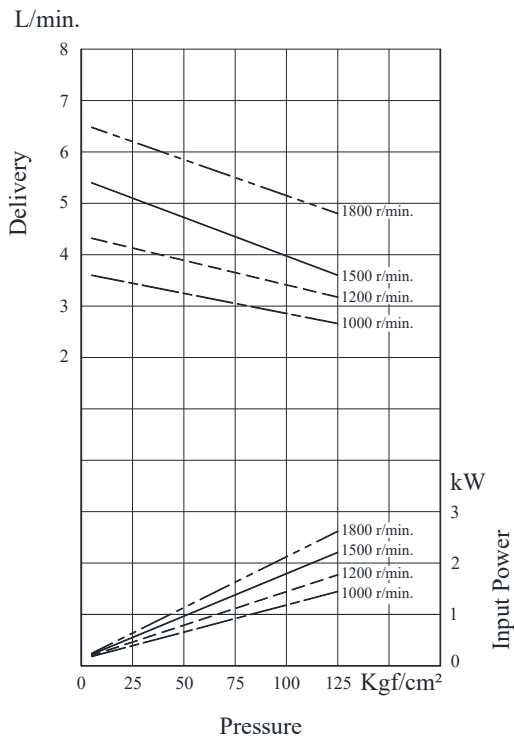

● SVP1 – 5

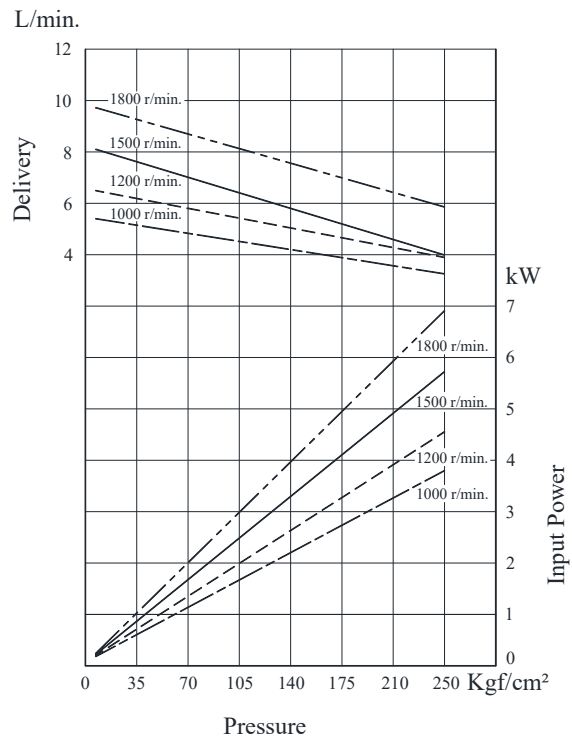

● SVP1 – 7

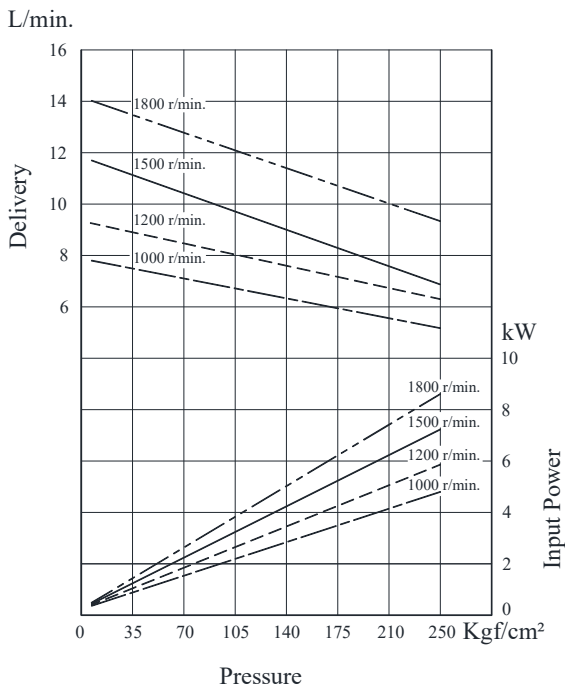

● SVP1 – 8

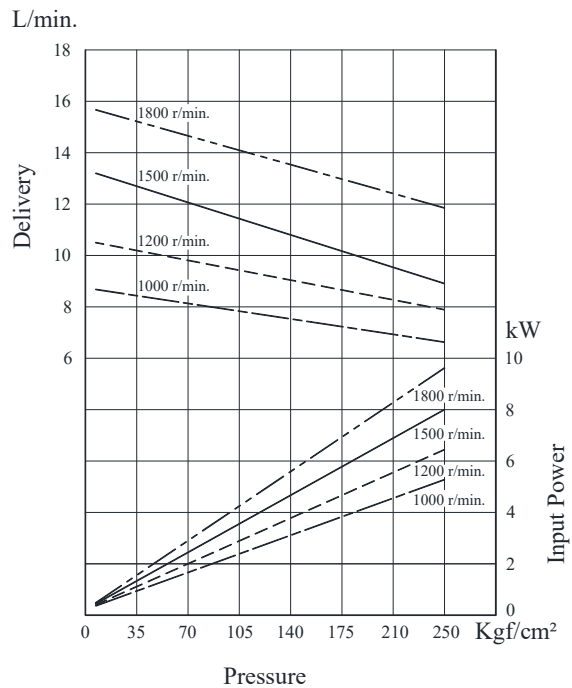

Typical Pump Characteristics Oil Viscosity 20 cSt [VG 32, Temp 50<sup>0</sup>C]

● SVP1 – 10

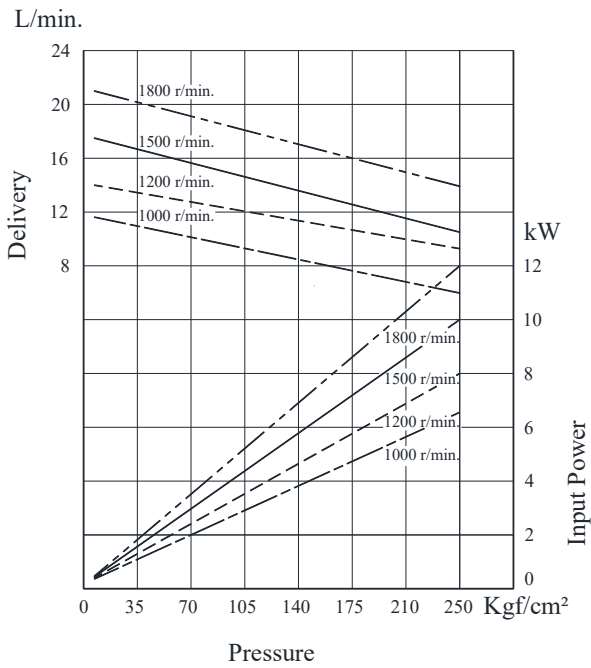

● SVP1 – 13

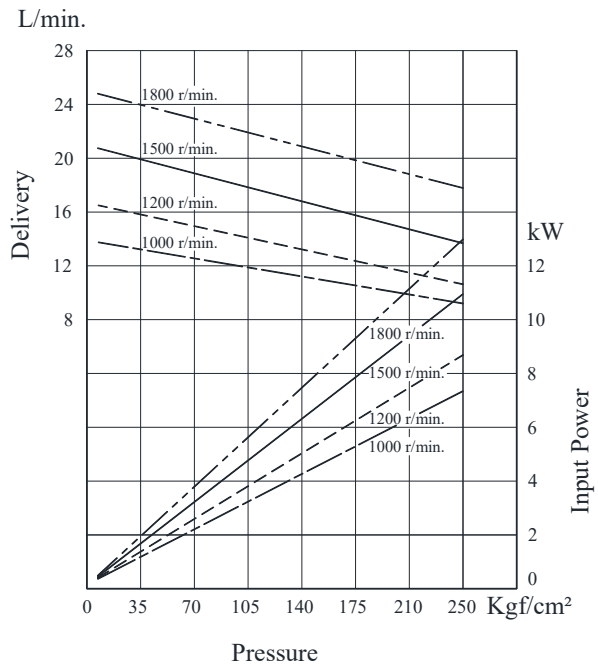

● SVP1 – 14

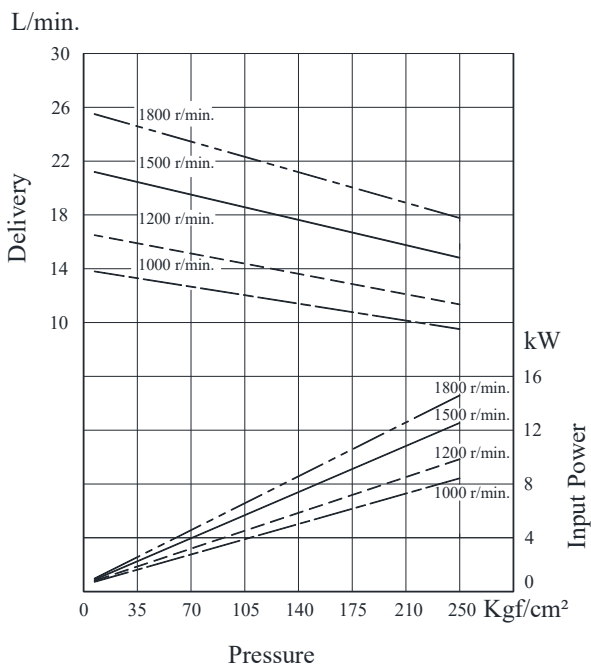

● SVP1 – 26

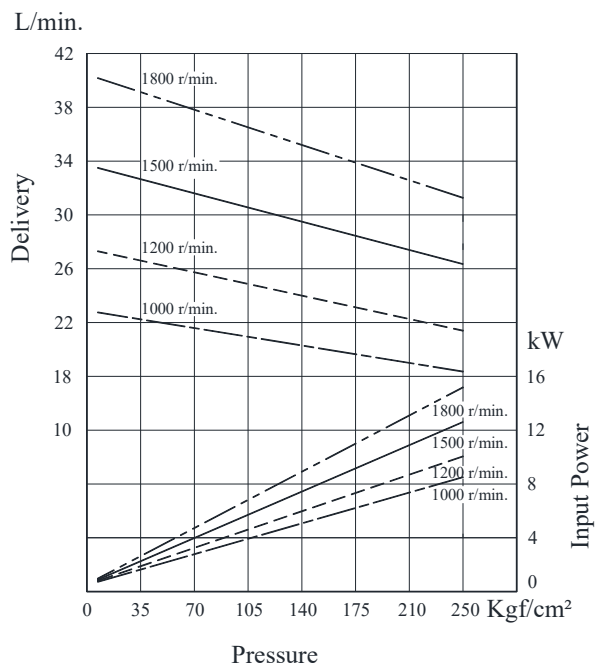

**SVP2 – Series Single Vane Pump**

These pumps have been developed especially for low noise operation. To comply with a wide range of applications, for instance the injection moulding machine industry. We provide a wide range of delivery volumes [10.8 ~ 47 cm<sup>3</sup>/rev.] for the pumps.

The main internal parts of the pumps are built as a cartridge kit. Therefore, maintenance can be easily done by simply changing the cartridges.



Graphic Symbol

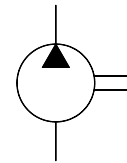

**Specifications**

Model Number	Geometric Displacement cm <sup>3</sup> /rev.	Max. Opr. Pressure Kg/cm <sup>2</sup>	Output Flow & Input Power kW	Shaft Speed Range r/min.		Mass Kg.	
				Max.	Min.	Flange Mounting	Foot Mounting
SVP2*-11	10.4	210	Refer Page 161, 162 & 163	1800*	600	16	18.7
SVP2*-17	16.1						
SVP2*-22	21.7						
SVP2*-25	24.1						
SVP2*-30	29.5						
SVP2*-33	31.7						
SVP2*-38	35.4						
SVP2*-43	40.8						
SVP2*-47	42.6						

\* For speeds above 1500 r/min., consult factory for information.

**Model Number Designation**

F-	SVP2	-L	-F	-11	-R	A	A	-10
Special Seals **	Series Number	Type of Mounting	Type of Pipe Connection	Nominal Delivery	Direction of Rotation	Discharge Port Position	Suction Port Position	Design* Number
As Viewed From Shaft End								
<b>F:</b> For Phosphate Ester type Fluids. (omit if not required)	<b>SVP2</b>	<b>L:</b> Foot Type  <b>F:</b> Flange Type	<b>F:</b> Flange Connection	<b>11</b> <b>17</b> <b>22</b> <b>25</b> <b>30</b> <b>33</b> <b>38</b> <b>43</b> <b>47</b>	<b>R:</b> Clockwise (Normal)  <b>L:</b> Counter-clockwise			<b>10</b>

\* Design numbers subject to change from 10 to 19, but installation dimensions remain as shown.

\* For instructions regarding changing the port positions, consult YUKEN INDIA LTD.

\*\* Before ordering the Special Seals, consult YUKEN INDIA LTD.

**SVP Series Single Vane Pump**

### Cartridge Kit Model Number

CSVP2	-11	-R	-10
Model Number	Nominal Delivery	Shaft Rotation	Design No.
CSVP2	11	R: Clockwise (Normal)	10
	17		
	22		
	25		
	30	L: Counter- Clockwise	
	33		
	38		
	43		
47			

\* For instructions regarding replacing cartridge kit, consult YUKEN INDIA LTD.

### Flanges

Note: Please refer page no. 725 for flange details.

### Spare Parts List

#### List of Seals

Sl. No.	Name of Part	Part Number	Qty.
1	O-Ring	SO-NA-P41	1
2	O-Ring	SO-NA- G80	1
3	O-Ring	SO-NB-G85	1
4	Backup-Ring	SO-BB-P41	1
5	Backup-Ring	SO-BB-G80	1
6	Oil Seal	ISPD 25388	1

Note: When ordering the seals, please specify the seal kit number KS-SVP2-10.



**SVP2-F-F-※-※※※-10**

● **Flange Mounting**

**DIMENSIONS IN MILLIMETRES**

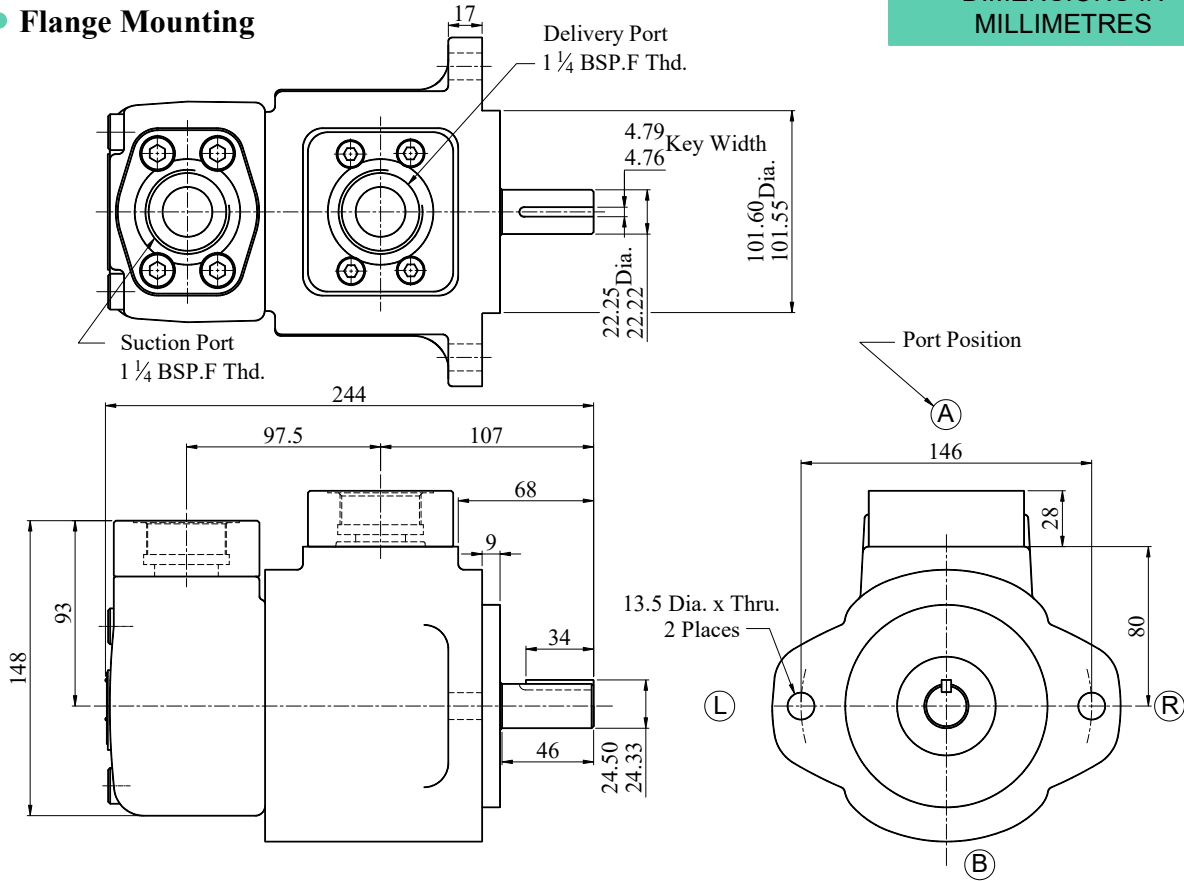

**SVP2-L-F-※-※※※-10**

● **Foot Mounting**

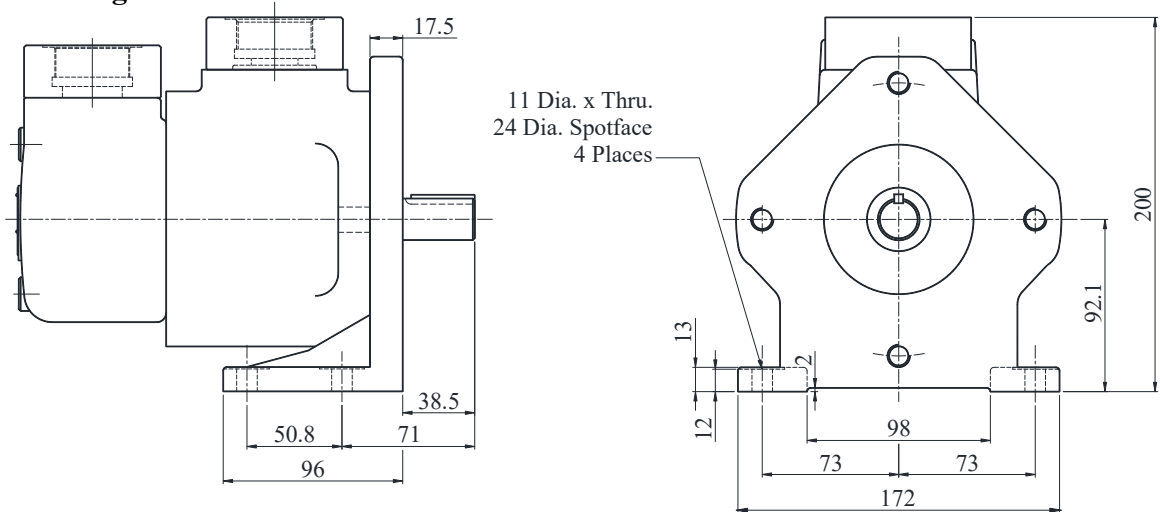

For further dimensions refer Flange Mounting.

**For Reference: Dimensions of Pipe Flange Mounting Surface**

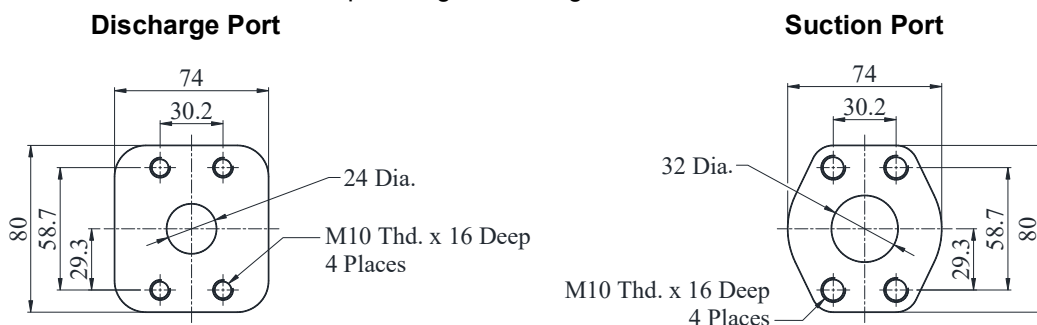

**SVP Series Single Vane Pump**

Typical Pump Characteristics Oil Viscosity 20 cSt [VG 32, Temp 50°C]

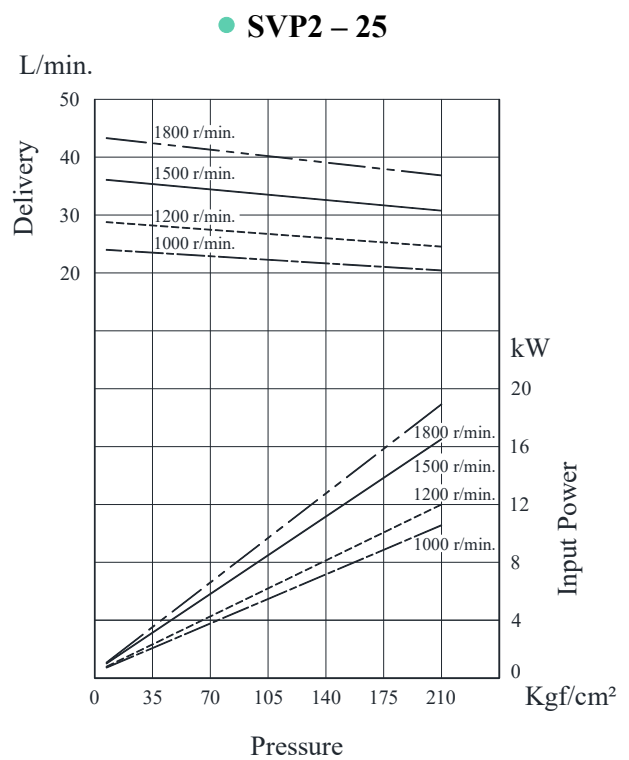
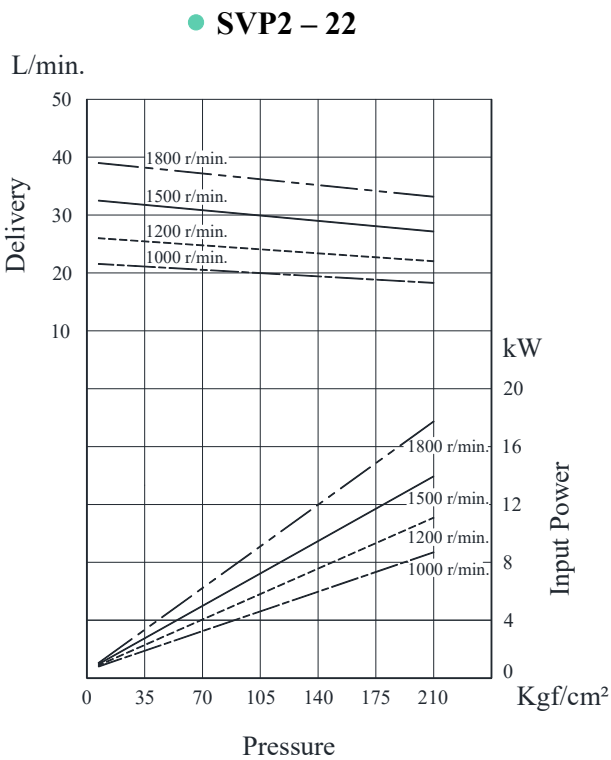
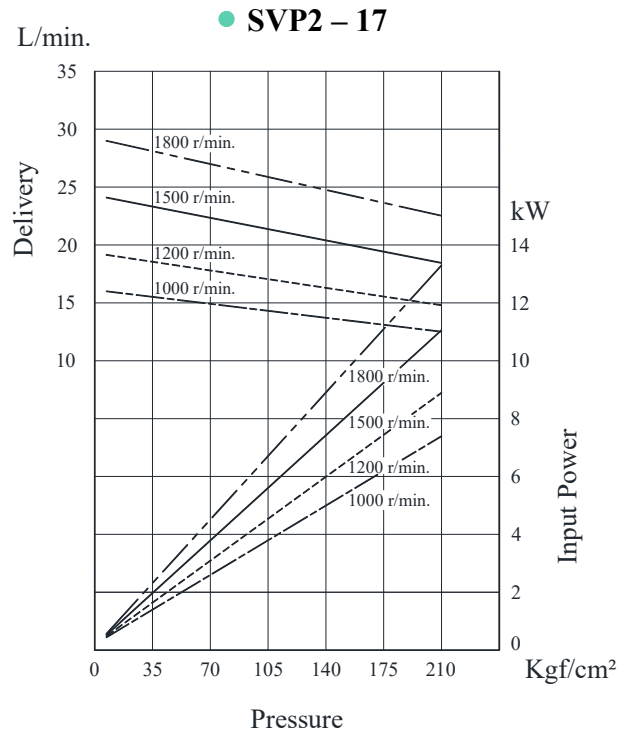
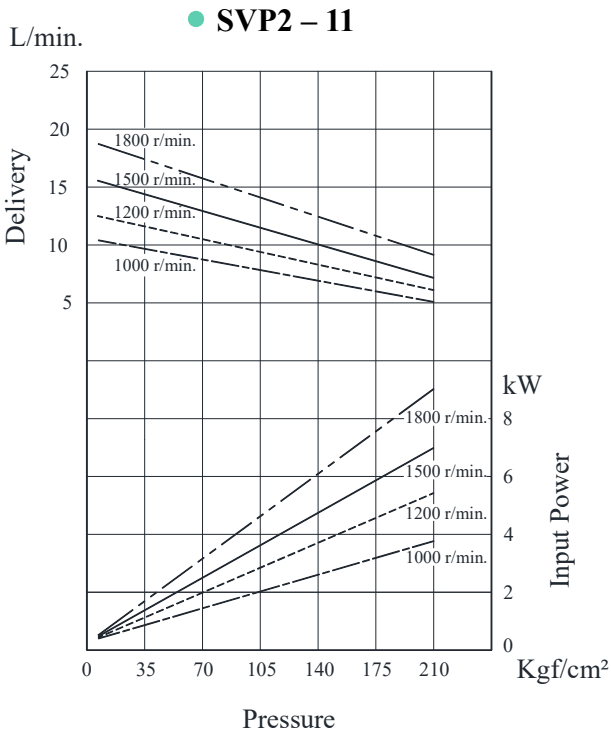

Typical Pump Characteristics Oil Viscosity 20 cSt [VG 32, Temp 50<sup>0</sup>C]

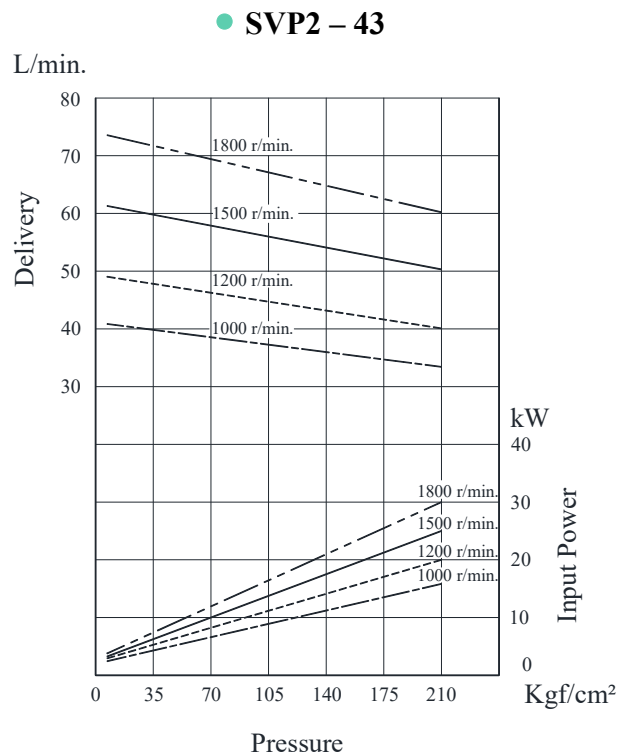
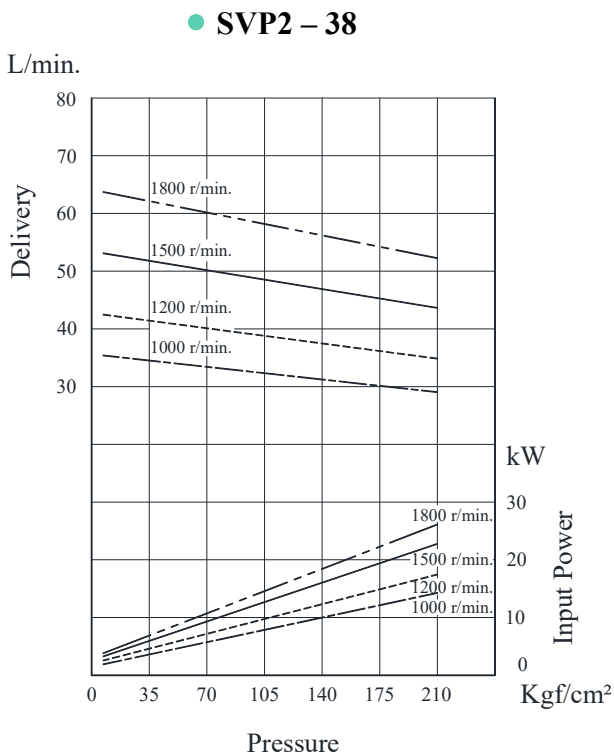
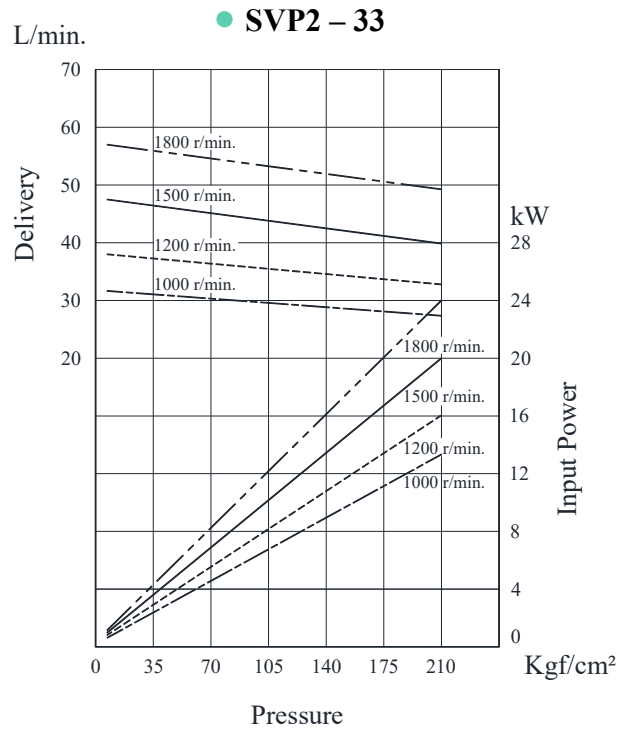
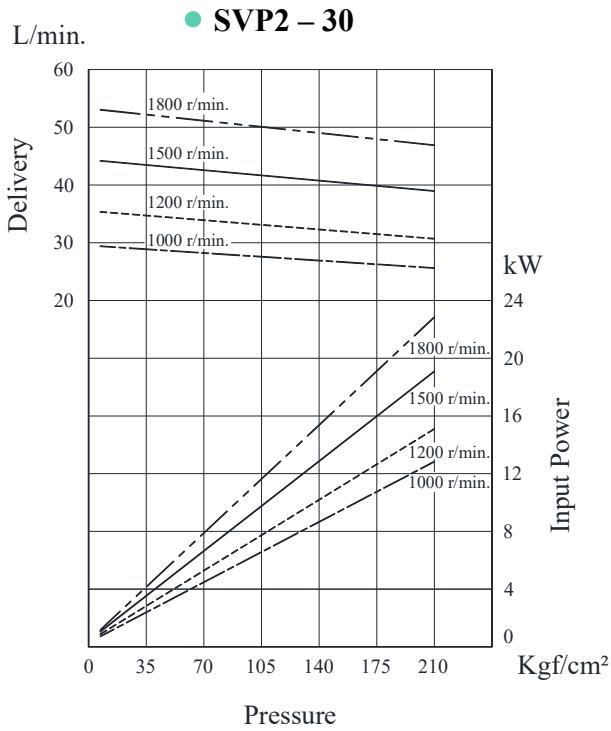

Typical Pump Characteristics Oil Viscosity 20 cSt [VG 32, Temp 50°C]

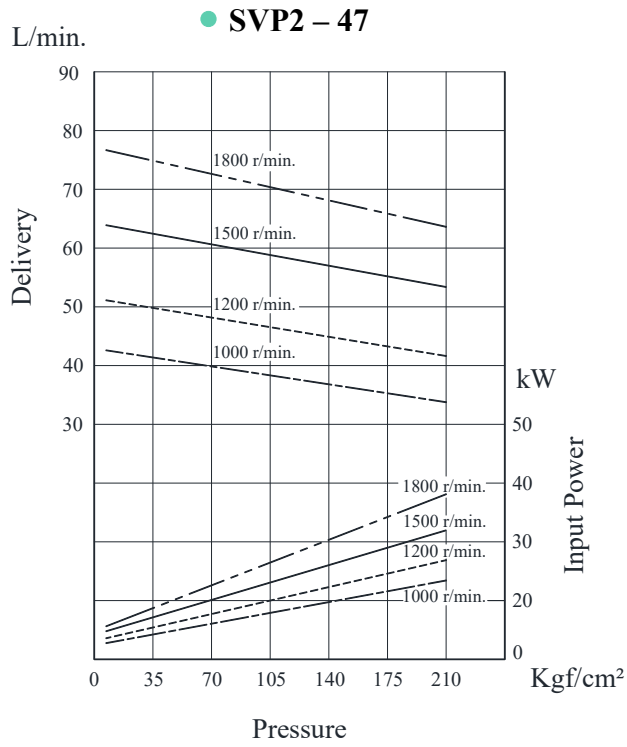

### SVP3 – Series Single Vane Pump

These pumps are widely used as a source of hydraulic power. They combine stable performance and robust construction with a wide range of delivery rates.

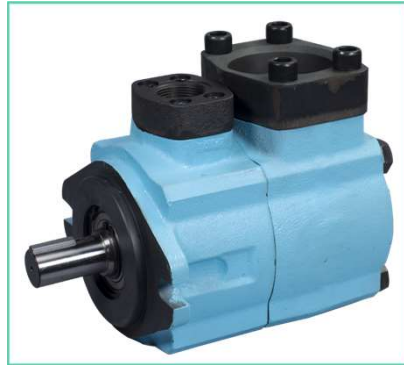

Graphic Symbol

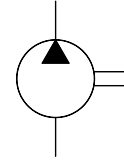

### Specifications

Model Number	Geometric Displacement cm <sup>3</sup> /rev.	Max. Opr. Pressure Kg/cm <sup>2</sup>	Output Flow & Input Power kW	Shaft Speed Range r/min.		Mass Kg.	
				Max.	Min.	Flange Mounting	Foot Mounting
SVP3-※-※-50	47	210	Refer Page 167 & 168	1800 *	600	38.5	45.1
SVP3-※-※-58	57						
SVP3-※-※-75	75						
SVP3-※-※-92	92						
SVP3-※-※-117	115						
SVP3-※-※-142	135						

\* For speeds above 1500 r/min., consult factory for information.

### Model Number Designation

F-	SVP3	-L	-F	-50	-R	A	A	-10
Special Seals **	Series Number	Type of Mounting	Type of Pipe Connection	Nominal Delivery	Direction of Rotation	Discharge Port Position	Suction Port Position	Design * Number
As Viewed From Shaft End								
<b>F:</b> For Phosphate Ester type Fluids. (omit if not required)	<b>SVP3</b>	<b>L:</b> Foot Type <b>F:</b> Flange Type	<b>F:</b> Flange Connection	<b>50</b> <b>58</b> <b>75</b> <b>92</b> <b>117</b> <b>142</b>	<b>R:</b> Clockwise (Normal) <b>L:</b> Counter-Clockwise			<b>10</b>

\* Design numbers subject to change from 10 to 19, but installation dimensions remain as shown.

\* For instructions regarding changing the port positions, consult YUKEN INDIA LTD.

\*\* Before ordering the Special Seals, consult YUKEN INDIA LTD.

### Cartridge Kit Model Number

CSVP3	-50	-R	-10
Model Number	Nominal Delivery	Shaft Rotation	Design No.
CSVP3	50	R: Clockwise (Normal)	10
	58		
	75	L: Counter- Clockwise	
	92		
	117		
142			

\* For instructions regarding replacing cartridge kit, consult YUKEN INDIA LTD.

### Flanges

Note: Please refer page no. 725 for flange details.

### Spare Parts List

#### List of Seals

Sl. No.	Name of Part	Part Number	Qty.
1	O-Ring	ARP 568-231	1
2	O-Ring	SO-NA-G120Y	1
3	O-Ring	SO-NB-G125	1
4	Back Up Ring	JIS W1516-G9	1
5	Back Up Ring	SO-BB-G120	1
6	Oil Seal	38 55 8	1

Note: When ordering the seals, please specify the seal kit number KS-SVP3-10.

**SVP3-F-F-※-※※※-10**

● **Flange Mounting**

DIMENSIONS IN MILLIMETRES

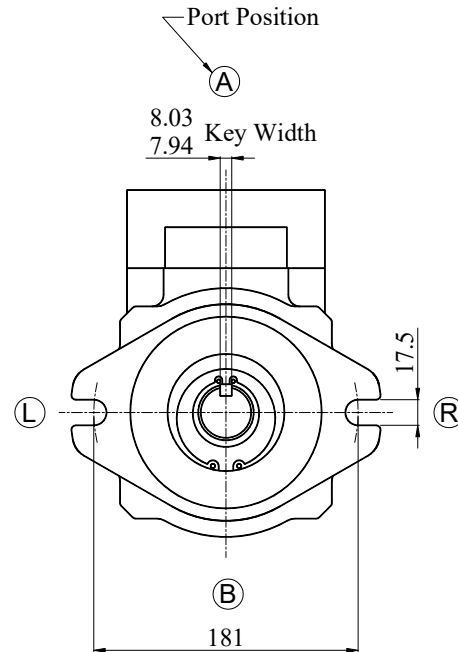
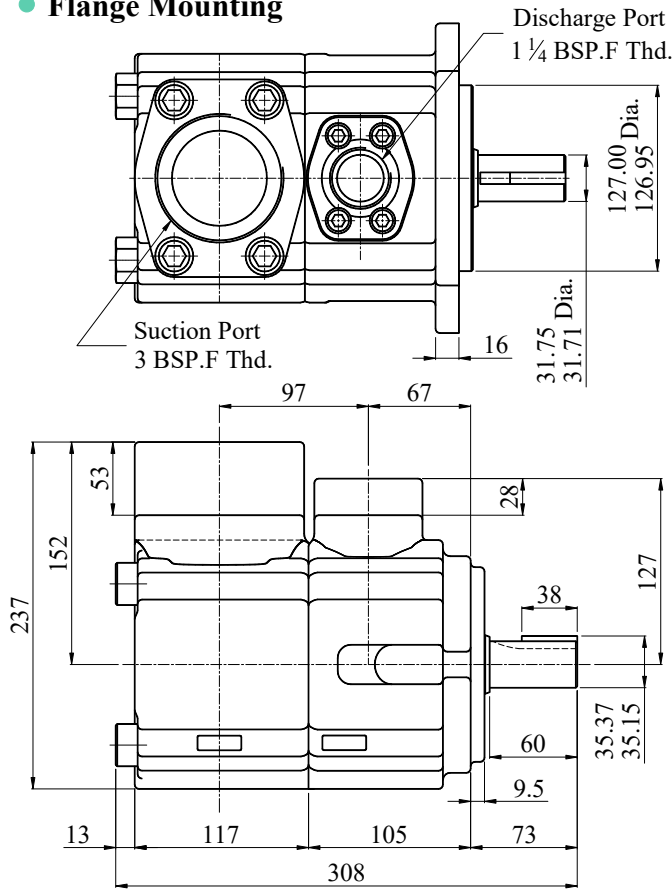

**SVP3-L-F-※-※※※-10**

● **Foot Mounting**

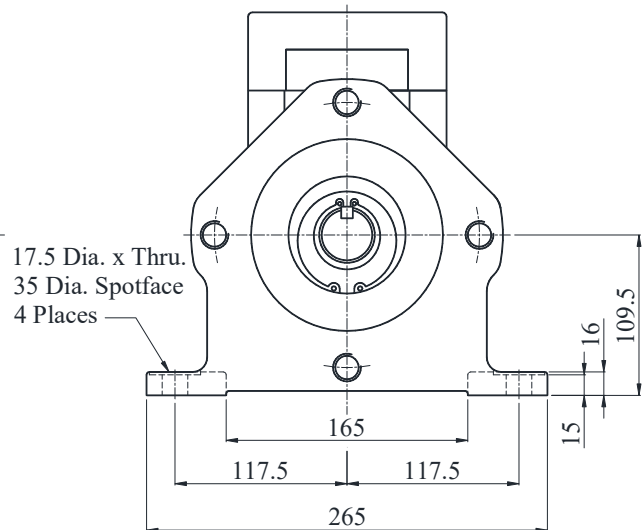
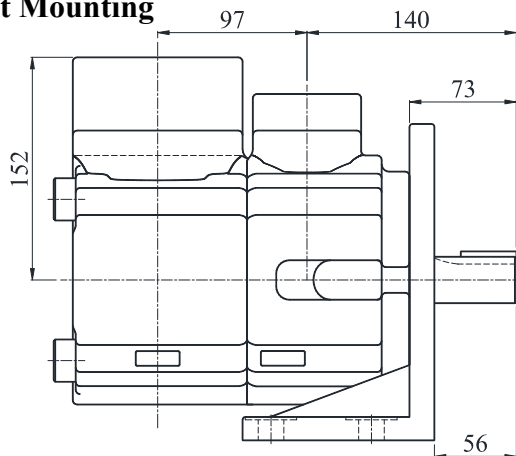

For further dimensions refer Flange Mounting.

**For Reference:** Dimensions of Pipe Flange Mounting Surface

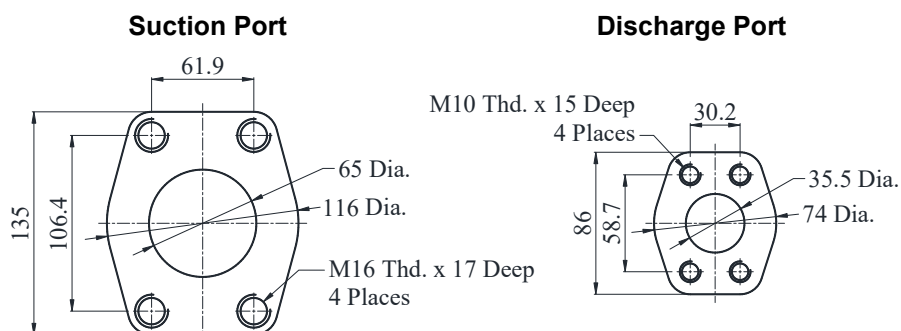

**SVP Series Single Vane Pump**

Typical Pump Characteristics Oil Viscosity 20 cSt [VG 32, Temp 50<sup>0</sup>C]

● SVP3 – 50

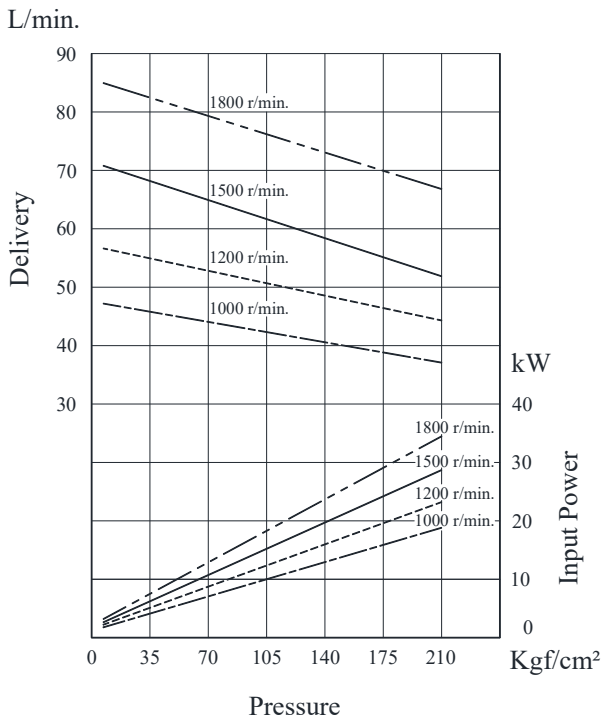

● SVP3 – 58

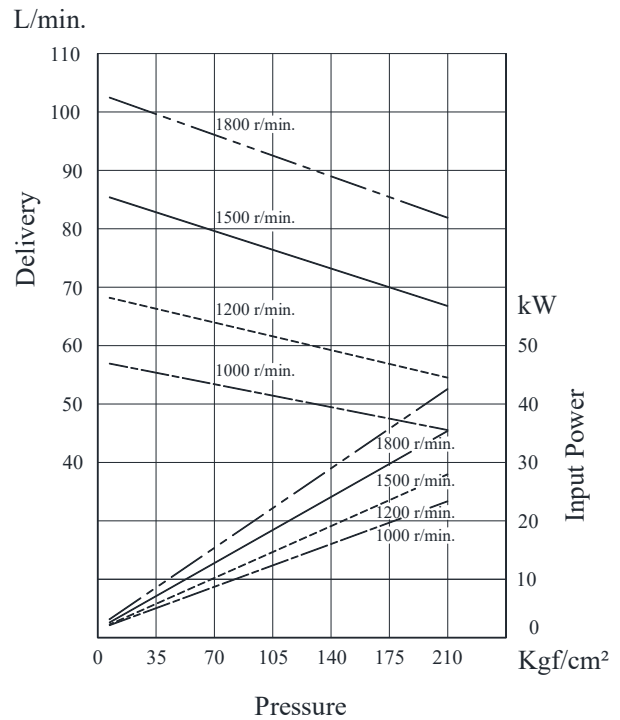

● SVP3 – 75

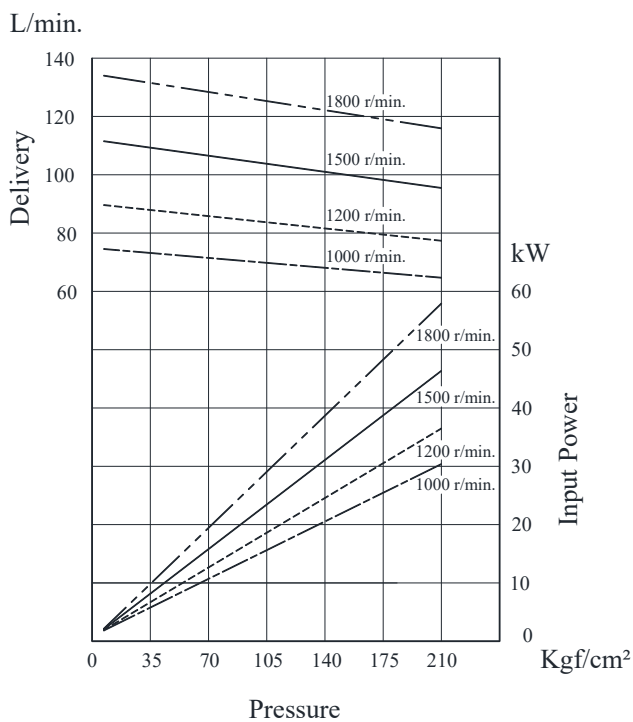

● SVP3 – 92

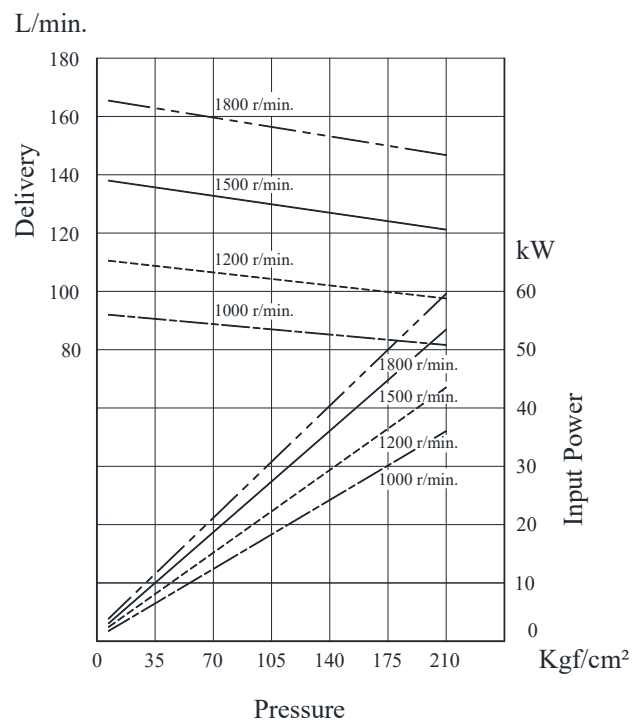



Typical Pump Characteristics Oil Viscosity 20 cSt [VG 32, Temp 50°C]

● SVP3 – 117

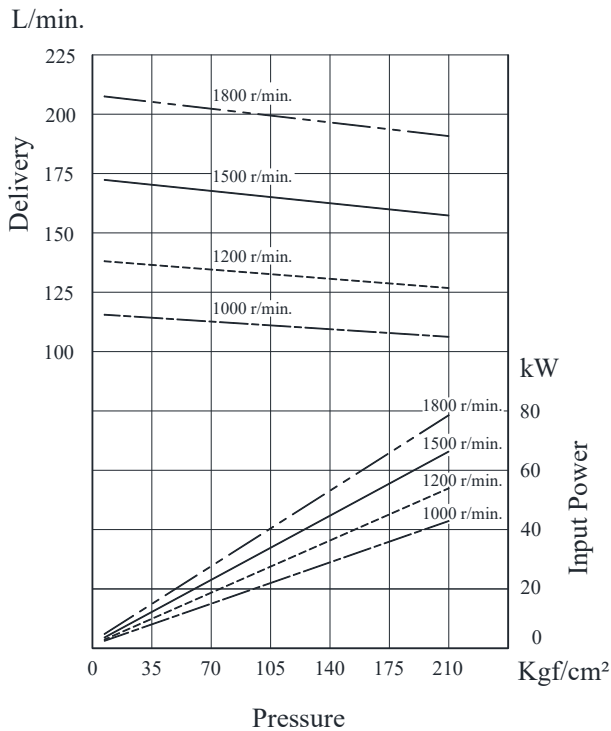

● SVP3 – 142

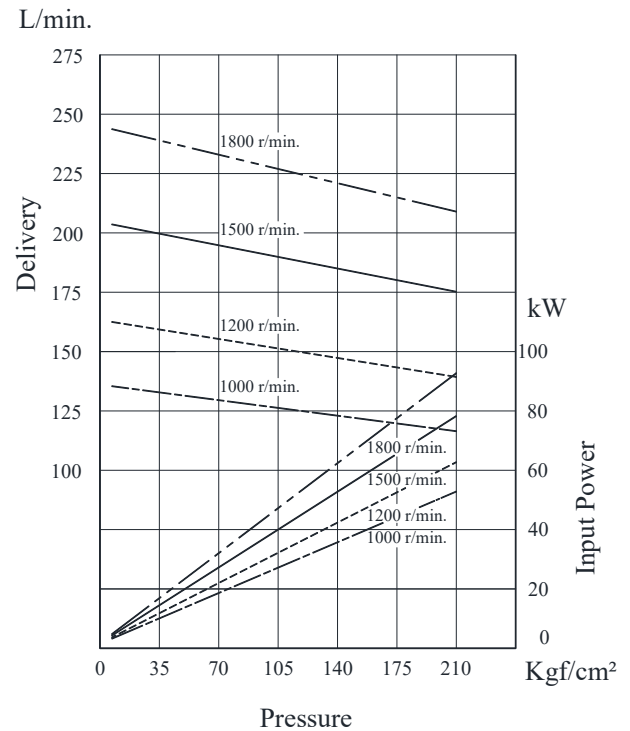

■ Cartridge Kit Model Number

Pump Model Numbers	Cartridge Kit Number #
SVP1T-5-※-R※-10	CSVP1-5-R-10
SVP1T-8-※-R※-10	CSVP1-8-R-10
SVP1T-14-※-R※-10	CSVP1-14-R-10
SVP2-※-F-22-R※※-10	CSVP2-22-R-10
SVP2-※-F-33-R※※-10	CSVP2-33-R-10
SVP2-※-F-43-R※※-10	CSVP2-43-R-10
SVP3-※-F-58-R※※-10	CSVP3-58-R-10
SVP3-※-F-92-R※※-10	CSVP3-92-R-10
SVP3-※-F-142-R※※-10	CSVP3-142-R-10

\* For instructions regarding replacing cartridge kit, consult YUKEN INDIA LTD.

# The above table does not include all combinations of cartridges available. Only a few representative samples are shown.