

## PVV20 SERIES

This is a variable displacement vane pump used in applications to save energy. When the hydraulic system reaches the 'set' pressure (e.g., end stroke of the cylinder), the delivery flow is cut-off reducing load on the motor and stopping unnecessary oil heating due to idle circulation. PVV20 series is widely used in machine tool clamping systems.

### Features

- High energy efficient operation with minimal power loss (Economical)
- Will eliminate relief valve and unloading valve from circuit.
- Compact and easy operation.
- Pressure stability.
- No pressure shoot.
- Low noise, silent operation.
- Long life.

### Specifications

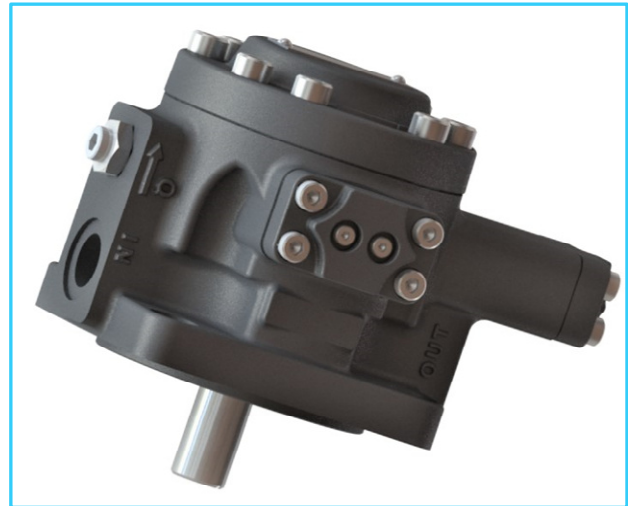

Model Number	Geometric Displacement cm <sup>3</sup> /rev.	Pr. Adj. Range kgf/cm <sup>2</sup>	Shaft Speed r/min.		Max. Setting Pressure kgf/cm <sup>2</sup>	Mass Kg.
			Min.	Max.		
PVV20-F-A-R-1080***	14	10 ~ 20	800	1800	20	8
PVV20-F-B-R-1080***		20 ~ 35			35	
PVV20-F-C-R-1080***	11.3	35 ~ 70			70	
PVV20-F-D-R-1080***		70 ~ 100			100	

### Graphic Symbol

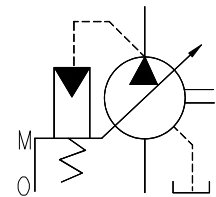

### Model Number Designation

F-	PVV	20	- F	- C	- R	- 10	80	H01	
Special seals**	Series Number	Nominal Flow at 1500 r/min. (L/min.)		Type of Mounting	Max. Operating Pressure kgf/cm <sup>2</sup>	Direction of Rotation (As viewed from shaft end)	Design Number*	Design Standard	Design Modification
F: For Phosphate Ester Type Fluids (Omit if not required)	PVV	20:	21	F: Flange Type (4 Bolt Mounting)	A: 10 ~ 20 * <sup>1</sup>	R: Clockwise (Normal)	10	80	<b>None:</b> Spigot dia. 95, Shaft dia. 19  <b>H01:</b> Spigot dia. 80, Shaft dia. 20  <b>H04:</b> Spigot dia. 80, Shaft dia. 19
			17		B: 20 ~ 35 * <sup>1</sup>				
			C: 35 ~ 70						
			D: 70 ~ 100 * <sup>1</sup>						

\* Design numbers subject to change, but installation dimensions remain as shown below.

\*\* Before ordering the Special Seals, consult YUKEN INDIA LTD.

\*<sup>1</sup> Consult YIL for availability.

**PVV20-F-※-R-1080**

DIMENSIONS IN MILLIMETRES

- Flange Mounting (4 Bolts)

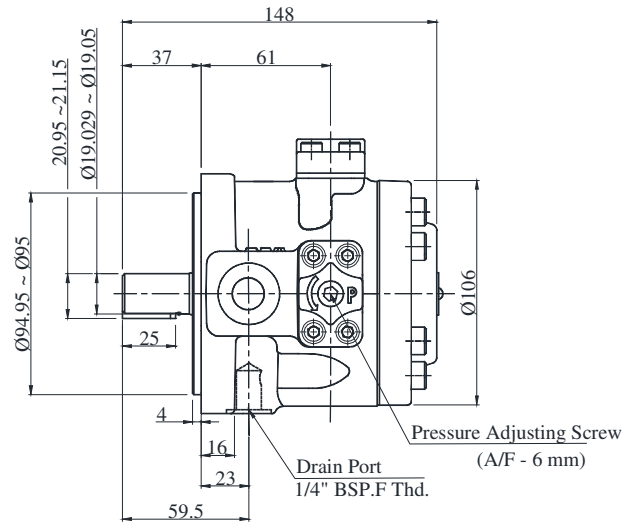
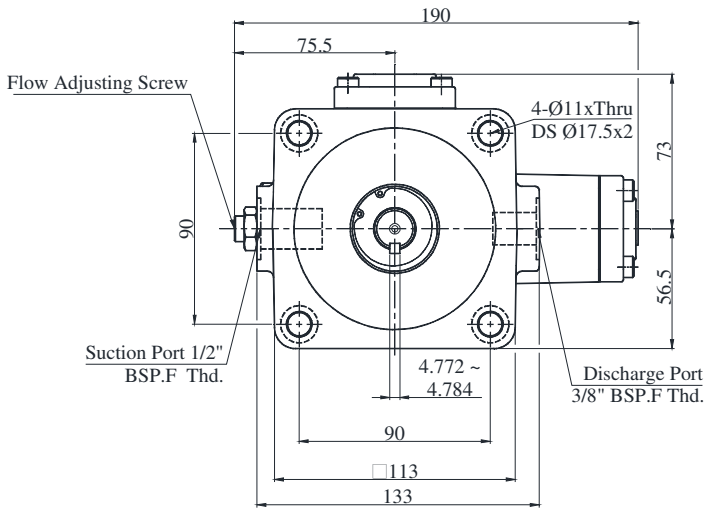

**PVV20-F-※-R-1080H01**

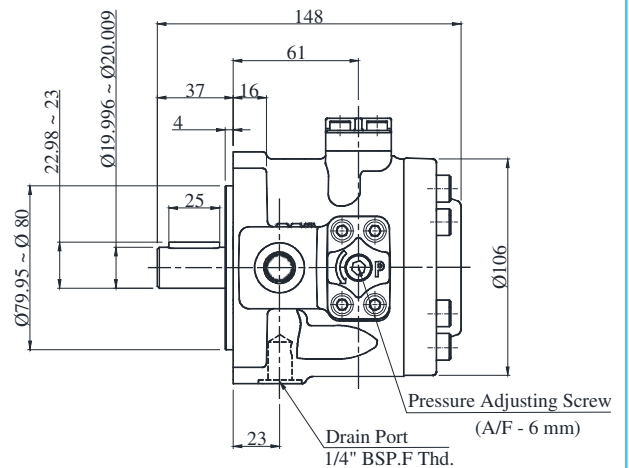
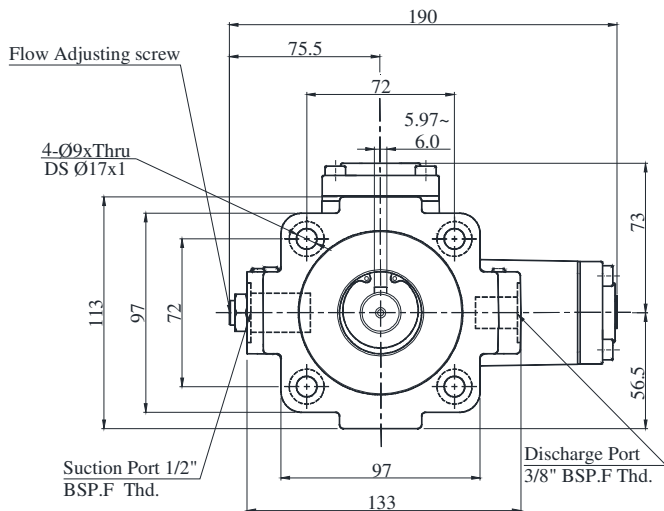

**PVV20-F-※-R-1080H04**

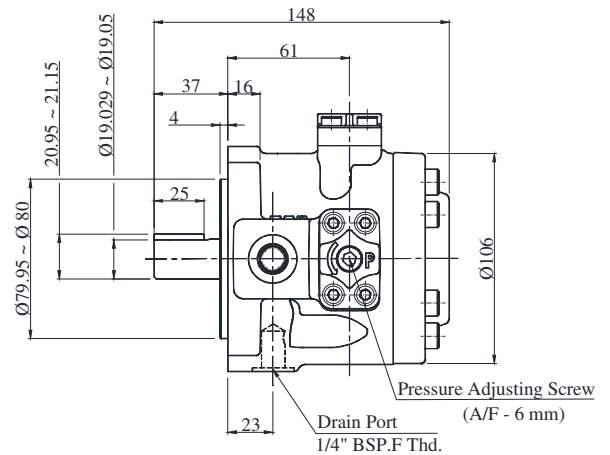
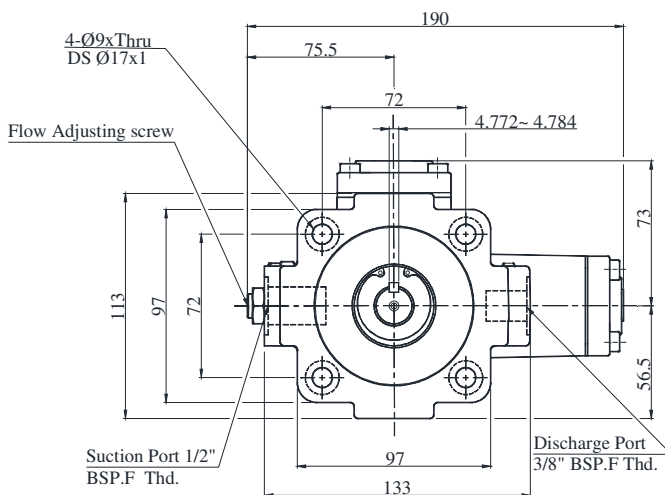

## Spare Parts List

### List Of Seals

Sl. No.	Parts Name	Part No.	Model Numbers	
			Qty.	
			PVV-20-※※	F-PVV-20-※※
1	Oil Seal	204010 (NBR) (NOK)	1	--
		204010 (Viton) (NOK)	--	1
2	O-Ring	SO-NA-P5	1	--
		SO-FA-P5	--	1
3	O-Ring	SO-NA-P12	1	--
		SO-FA-P12	--	1
4	O-Ring	D-PKH4-0382 (NBR)	1	--
		D-PKH4-0562 (Viton)	--	1
5	O-Ring	SO-NB-G70	1	--
		SO-FB-G70	--	1

Note: When ordering the seals, please specify the seal kit number from the table below.

### List Of Seal Kits

Pump Model Numbers	Seal Kit Numbers
PVV20-F-※-R-1080※※※	KS-PVV20-1080
F-PVV20-F-※-R-1080※※※	F-KS-PVV20-1080

## Typical Pump Characteristics

Oil Viscosity 41 cSt [ISO VG 32, Temp 50<sup>0</sup> C]

### PVV20-F-A-R-1080※※※

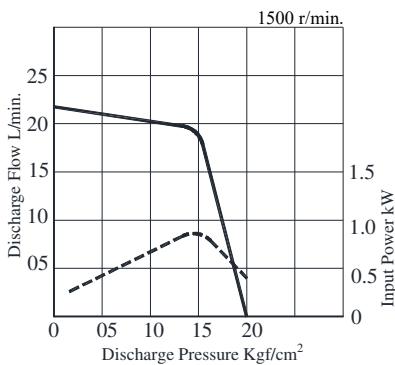

### PVV20-F-D-R-1080※※※

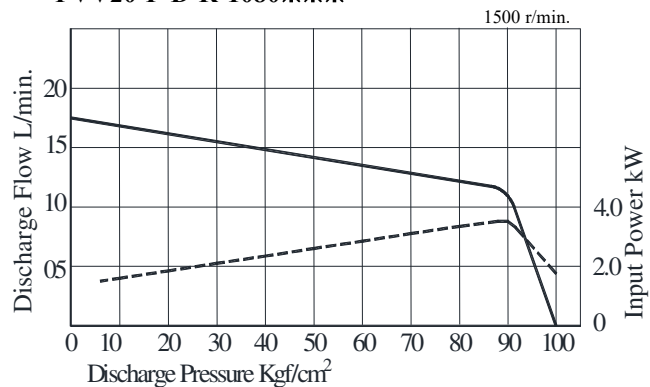

### PVV20-F-B-R-1080※※※

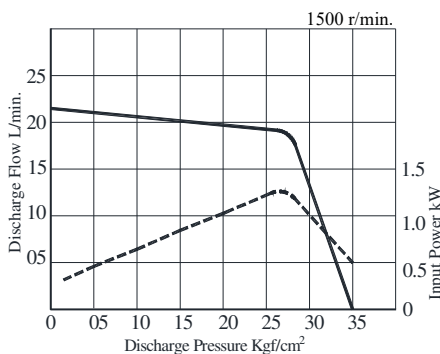

### Noise Characteristics

One meter horizontally away from pump head cover

### PVV20-F-C-R-1080※※※

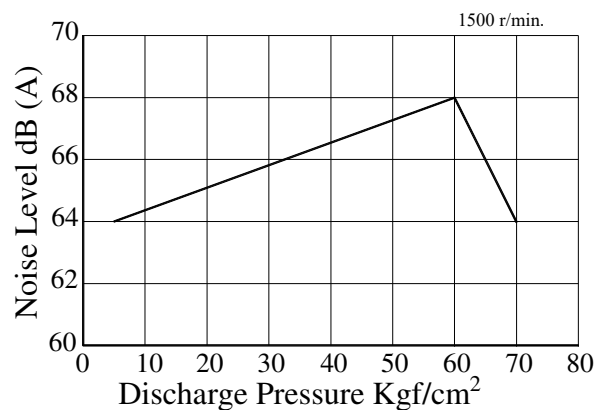

### PVV20-F-C-R-1080※※※

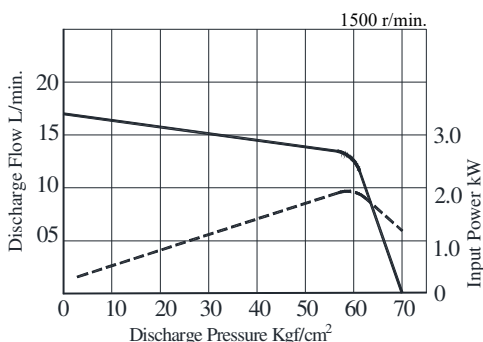

## ■ Handling

- **Rotation Direction** : The direction of rotation is always in clockwise (rightward) when viewed from the shaft side.
- **Drain** : Drain piping must be direct piping up to a point that is below the tank fluid level, and back pressure due to pipe resistance should not exceed 0.3 kgf/cm<sup>2</sup>.
- **Discharge Volume Adjustment** : The discharge flow rate is decreased by clockwise (rightward) rotation of the Flow adjusting screw, and increased by counter-clockwise (leftward) rotation. Loosen the lock nut before making adjustments. After adjustment is complete, re-tighten the lock nut. The graph below provides general guidelines for the relationship between the rotation angle of the flow adjusting screw and the no-load discharge rate.

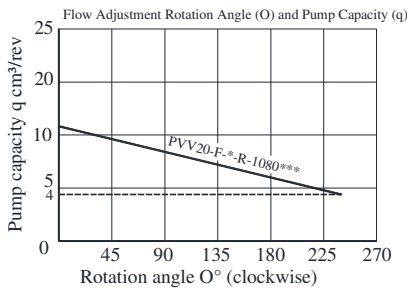

However: Q: No-load Discharge Rate Q l/min  
 q: Volume cm<sup>3</sup>/rev  
 N: Revolution Speed min<sup>-1</sup>

Note:- The values indicated are at maximum pump discharge volume with the flow volume adjusting screw at the 0° position. The broken line shows the flow volume adjustment range lower limit value.

- **Pressure Adjustment** : Pressure is decreased by clockwise (rightward) rotation of the Pressure adjusting screw, and increased by counter-clockwise (leftward) rotation.
- **Factory Default** : P-Q Settings (Standard Model)

Factory Default Pressure Settings	
	kgf/cm <sup>2</sup>
A	20
B	35
C	70
D	100

- Flow Rate Setting = Maximum flow rate for model as indicated in the catalogue
- Pressure Setting = Pressure shown in table to the right
- Provide an air bleed valve in circuits where it is difficult to bleed air before startup.

- **Initial Operation** : Before operating the pump for the first time, put the pump discharge side into the no-load state and then repeatedly start and stop the motor to bleed all air from inside the pump and the suction piping. After confirming that the pump is discharging oil, continue the no load operation for at least 10 minutes to discharge all the air from the circuit
- **For the hydraulic operating fluid**, use an R&O type and wear resistant type of ISO VG32 to 68 or equivalent (viscosity index of at least 90). Use hydraulic operating fluid that provides kinematic viscosity during operation in the range of 20 to 150mm<sup>2</sup>/s.
- **The operating temperature** range is 15 to 60°C. When the oil temperature at start up is 15°C or less, perform a warm-up operation at low pressure and low speed until the oil temperature reaches 15°C. Use the pump in an area where the temperature is within the range of 0 to 60°C.
- **Suction pressure** is -0.03 to +0.03MPa (-0.3 to +0.3kgf/cm<sup>2</sup>), and the suction port flow rate should be to greater than 2m/sec.
- Avoid pulley, gear, and other drive systems that impart a radial or thrust load on the end of the pump shaft. Mount the pump so its pump shaft is oriented horizontally.
- Provide a suction strainer with a filtering grade of about 100 μ m (150 mesh). For the return line to the tank, use a 25 μ m line filter.
- Manage hydraulic operating fluid so contamination is maintained at class NAS10 or lower. Take care to avoid contamination with water and other foreign matter, and watch out for discoloration. Whitish fluid indicates that air has contaminated the fluid, and brownish fluid indicates the fluid is dirty.
- Contact YIL about using water- and glycol-based hydraulic operating fluids.
- At start up, repeat the inching operation (start-stop) to bleed air from the pump and pipes.
- Equip an air bleed valve in circuits where it is difficult to bleed air before start up.
- To ensure proper lubrication of the pump's rubbing surfaces, supply oil to the interior of the pump before starting operation.
- When centring the pump shaft, eccentricity with the motor shaft should be no greater than 0.05mm. Use a pump mounting base of sufficient rigidity. The angle error should be no greater than 1°.