

Remote Control Relief Valves

This valve is used as a remote control valve for pilot operated type pressure control valves.

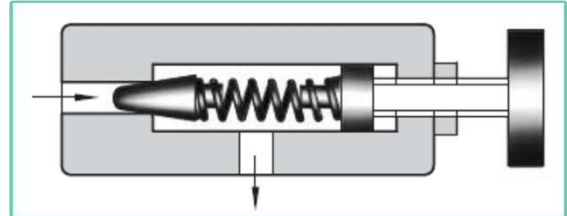

Graphic Symbol

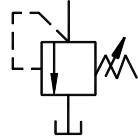

Specifications

Model Number		Max. Operating Pressure Kgf/cm ²	Max. Flow L/min.	Mass Kg.	
Threaded Connection	Sub-Plate Mounting			YBT Type	YBG Type
YBT-01-※-250-1080	YBG-01-※-250-1080	250	4	1.6	1.4

Model Number Designation

F-	YB	T	-01	-F	-250	-10	80
Special Seals**	Series Number	Type of Mounting	Valve Size	Panel Mounting	Max. Operating Pressure Kgf/cm ²	Design Number	Design Standard
F: Special Seals for Phosphate Ester Type Fluids. (Omit if not required)	YB: Remote Control Relief Valves	T: Threaded Connection	01	F: Panel Mounting (Omit if not Required)	250	10	80
		G: Sub-Plate Mounting		---			

** Before ordering the Special Seals, consult YUKEN INDIA LTD.

Instructions

- To adjust the pressure, loosen the lock nut and turn the handle slowly clockwise for higher pressure or anti-clockwise for lower pressures. After adjustments, do not forget to tighten the lock nut.
- Piping of the tank line should not be connected to any tank line of the other valves, but connected directly to the tank.

Attachment

- Mounting Bolts**

Valve Model	Socket Head Cap Screw	Qty.	Bolt Kit Ordering Code
YBG-01	M8 x 30Lg.	4	BKYBG-01-10

Sub-plate

Valves Model Number	Sub – Plate Model Number	Thread Size	Mass Kg.
YBG-01	YBGM-01-1080	1/4 BSP.F	0.7

- Sub-plates are available, specify sub-plate model number from the table above.
When sub-plates are not used the mounting surface should have a good machined finish.

● **YBT-01-※ -250-1080**

DIMENSIONS IN MILLIMETRES

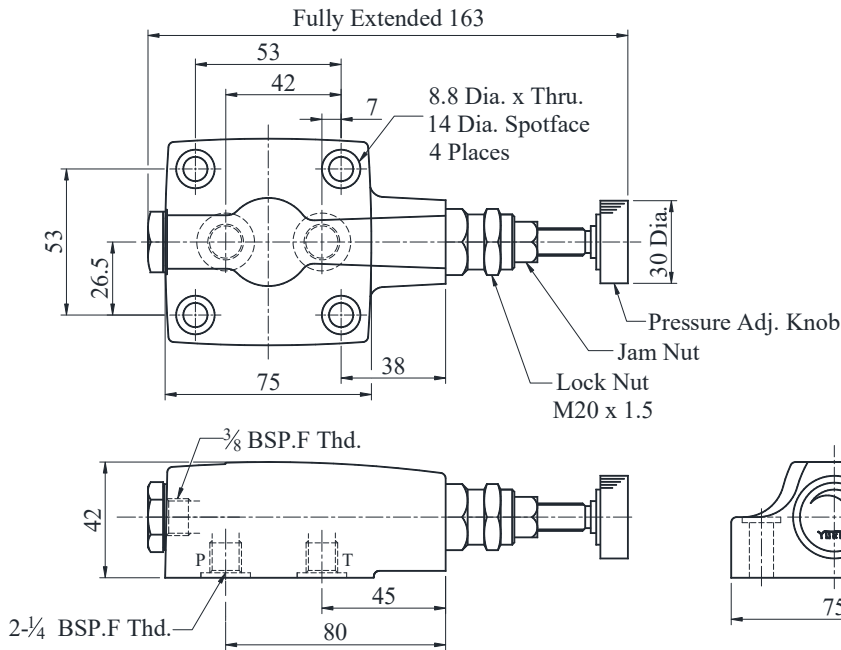

● **YBG-01-250-1080**

● **Sub-Plate: YBGM-01-1080**

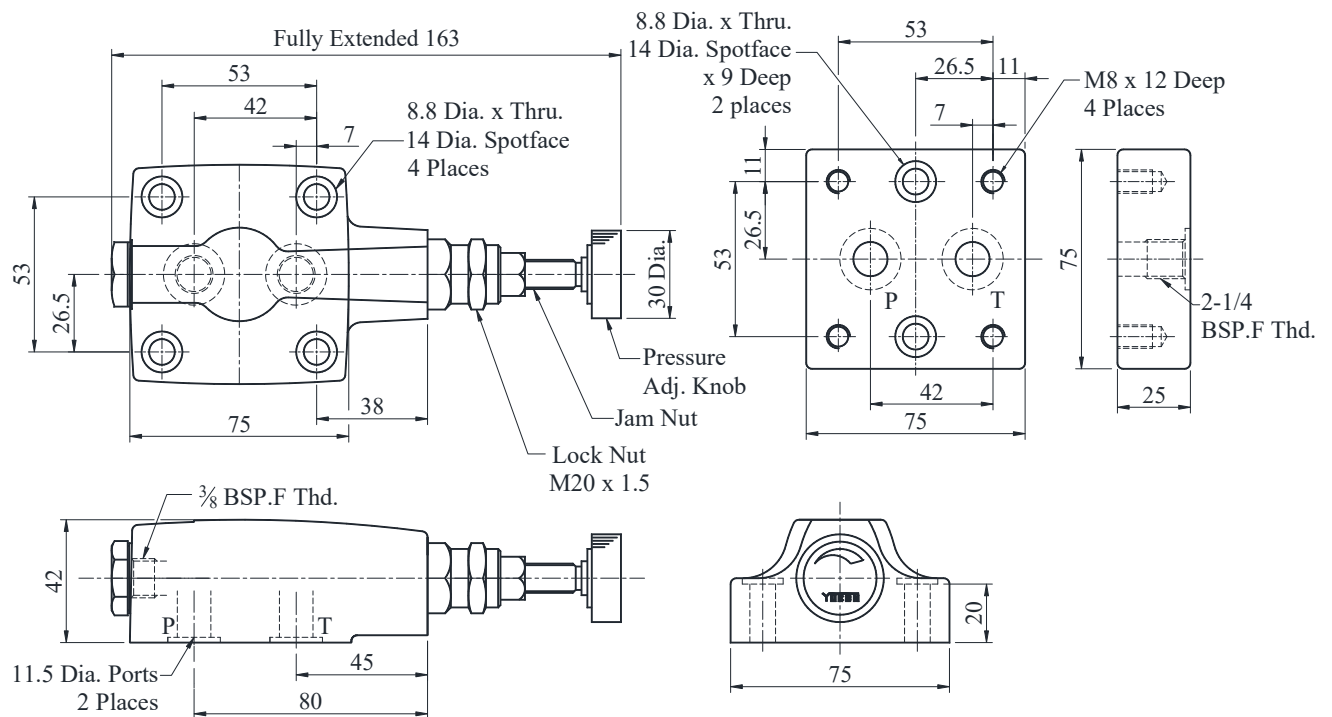

● **YBT-01-F-250-1080**

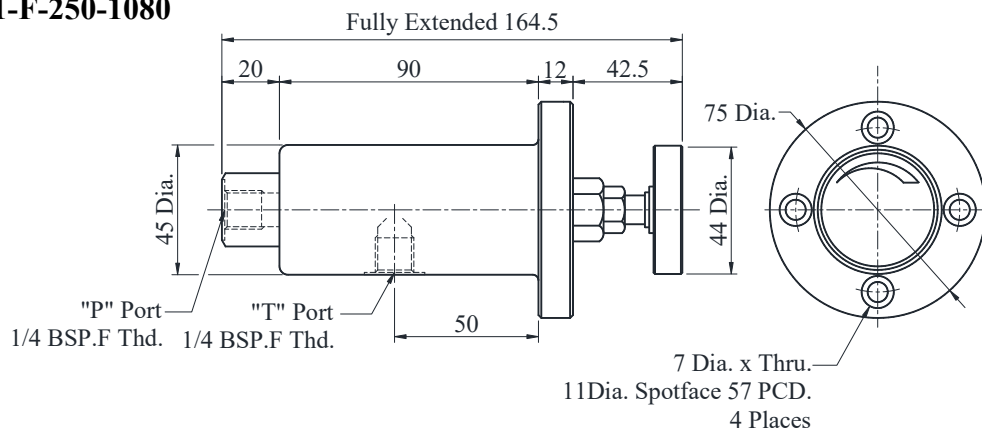

Remote Control Relief Valves

Direct Type Relief Valves

This valve is used in hydraulic system to prevent damage due to over pressure and to adjust the maximum system pressure of small capacity.



Specifications

Model Number	Max. Operating Pressure Kgf/cm ²	Pres. Adj. Range Kgf/cm ²	Max. Flow L/min.	Mass Kg.
YBT-02-※-※-1080	160	(Note)	20	1.5
YBG-02-※-10				1.6

Graphic Symbol

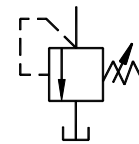

Note: Refer to the Model Number Designation.

Model Number Designation

F-	YB	T	-02	-X	-B	-10	※
Special Seals **	Series Number	Type of Mounting	Valve Size	Port Size	Pres. Adj. Range Kgf/cm ²	Design Number	Design Standard
F: Special Seals for Phosphate Ester Type Fluids. (Omit if not required)	YB: Direct Type Relief Valves	T: Threaded Connections	02	None: Std. 1/4	A: 3 ~ 40	10	80
		G: Sub-Plate Mounting		X: 3/8	B: 10 ~ 70 C: 35 ~ 140 D: * ~ 160 E: 2 ~ 10		
				--		10	-

* Refer to the Minimum Adjustment Pressure Characteristics on Page no.245

** Before ordering the Special Seals, consult YUKEN INDIA LTD.

Instructions

- To adjust the pressure, loosen the lock nut and slowly turn the handle clockwise for higher pressure or anti-clockwise for lower pressures. After adjustments, do not forget to tighten the lock nut.
- Piping of the tank line should not be connected to any tank line of the other valves, but connected directly to the tank.

Attachment

- Mounting Bolts**

Valve Model	Socket Head Cap Screw	Qty.	Bolt Kit Ordering Code
YBG-02	M5 x 55Lg.	4	BKYBG-02-10

Sub-plate

Valves Model	Sub - Plate Model Number	Thread Size	Mass Kg.
YBG-02	YBGM-02-1080	1/4 BSP.F	0.7

- Sub-plates are available, specify sub-plate model number from the table above. When sub-plates are not used the mounting surface should have a good machined finish.

● **YBG-02-※-10**

DIMENSIONS IN MILLIMETRES

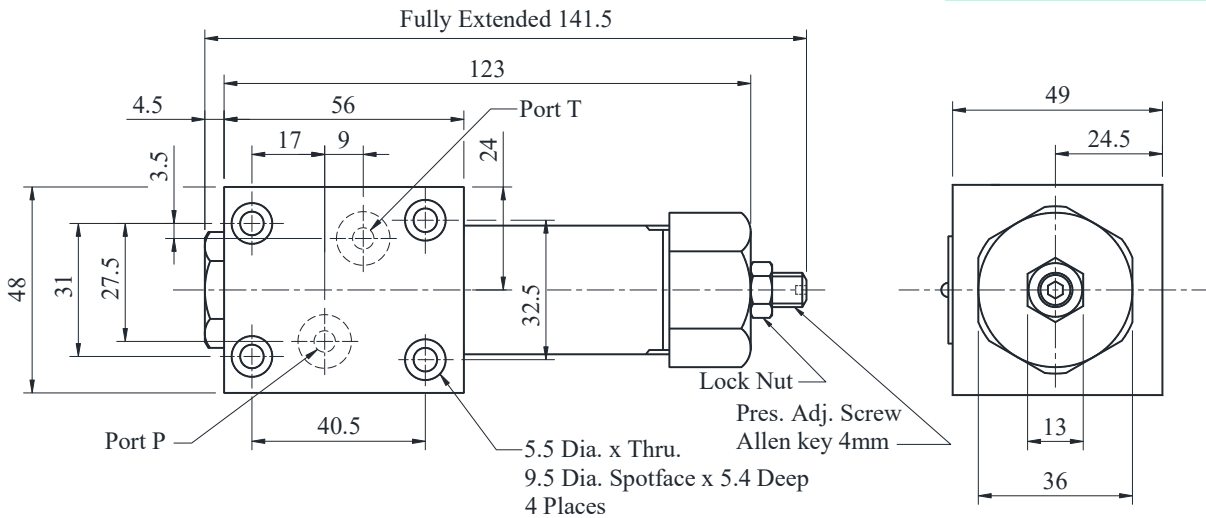

● **YBT-02-※-※-1080**

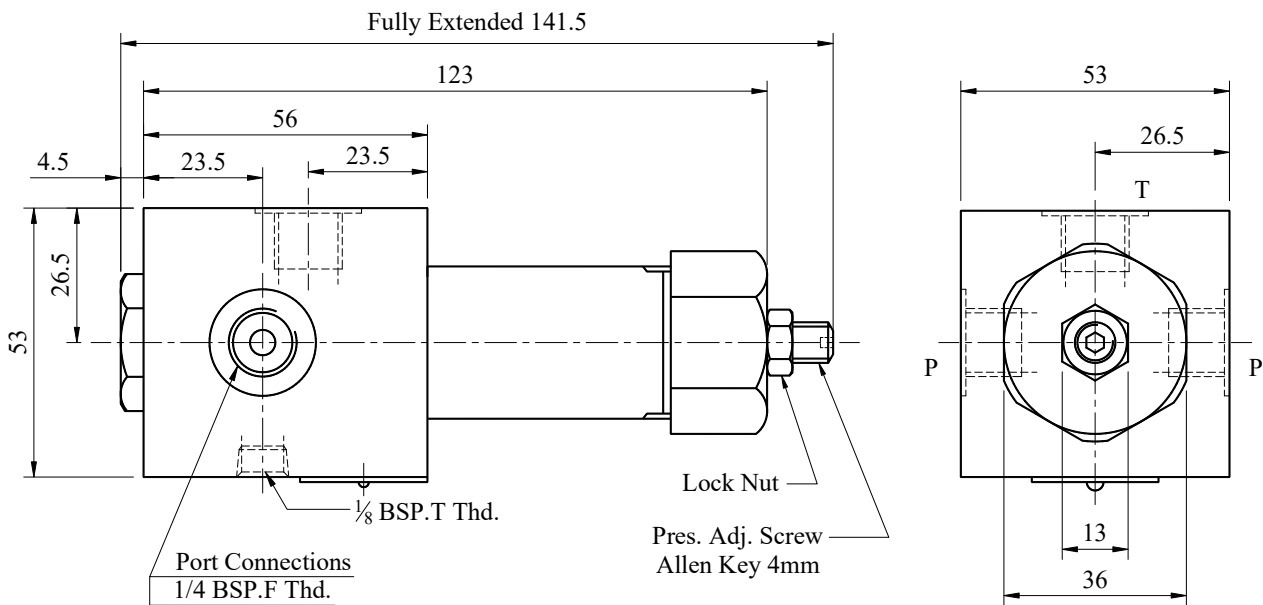

● **Sub-plate: YBGM-02-1080**

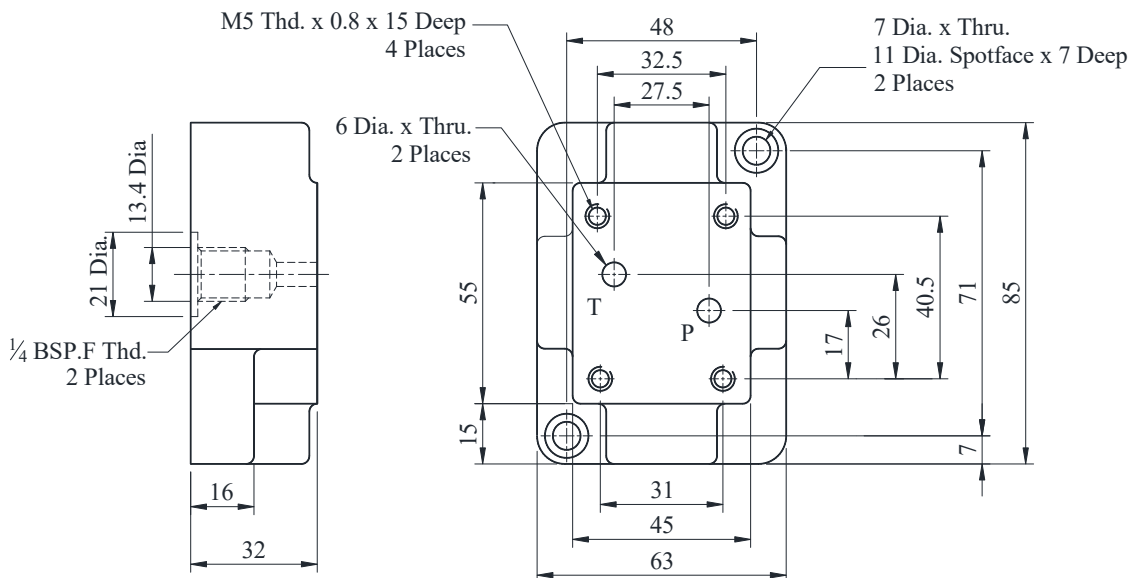

● YB※-02

■ Nominal Override Characteristics

■ Min. Adjustment Pressure

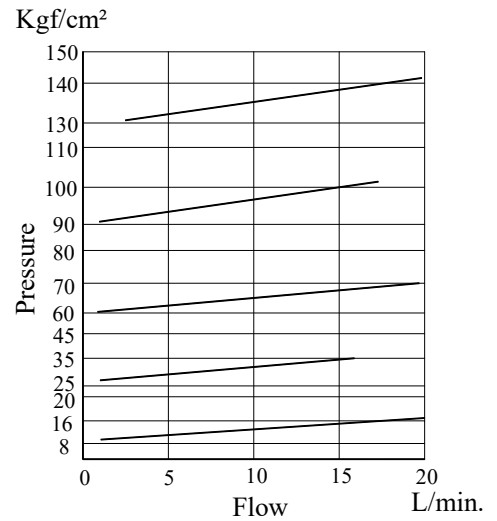
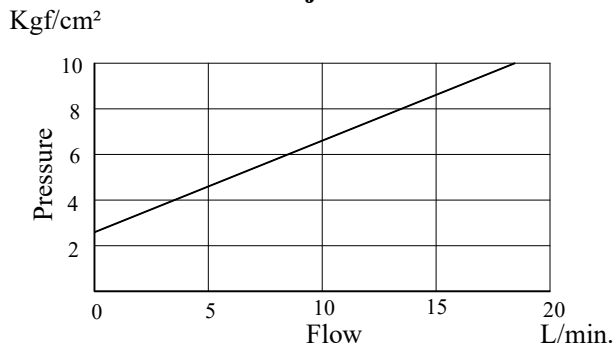

■ Spare Parts List

● List of Seals

Sl. No.	Name of Parts	Parts Number	Quantity				
			YBT-01	YBG-01	YBG-01-F	YBG-02	YBT-02
1	O-Ring	SO-NA-P14	-	2	1	-	-
2	O-Ring	SO-NA-P9	1	1	1	2	-
3	O-Ring	SO-NA-P20	-	-	-	1	1
4	O-Ring	SO-NB-P18	-	-	-	2	2

Note : When ordering the seals, please specify the seal kit number from the table below.

● List of Seal Kits

Model Numbers	Seal Kit Numbers
YBT-01	KS-YBT-01-1080
YBG-01	KS-YBG-01-1080
YBG-01-F	KS-YBG-01-F-1080
YBT-02	KS-YBT-02-1080
YBG-02	KS-YBG-02-1080

Cartridge Type Relief Valves

These valves are used in a hydraulic circuit to prevent damage due to excess pressure and to adjust the max. pressure of small capacity.

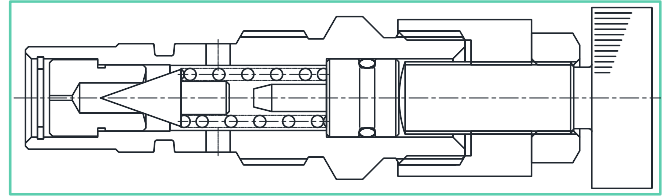

Specifications

Model Number	Max. Operating Pressure Kgf/cm ²	Pres. Adj. Range Kgf/cm ²	Max. Flow L/min.	Mass Kg.
CB-1-1080	140	18 ~ 140	1	0.45

Model Number Designation

C	B	1	-10	80
Cartridge Type	Relief Valve	Valve Size	Design Number	Design Standard
C	B	1	10	80

Graphic Symbol

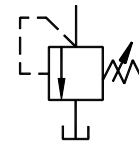

Instructions

Pressure Adjustment

Loosen Jam-nut and turn knob clockwise for increase in pressure and anti-clockwise for decrease in pressure.

Care in Application

Tank Line of this valve is to be directly connected to tank.

Flow Vs Pressure

DIMENSIONS IN MILLIMETRES

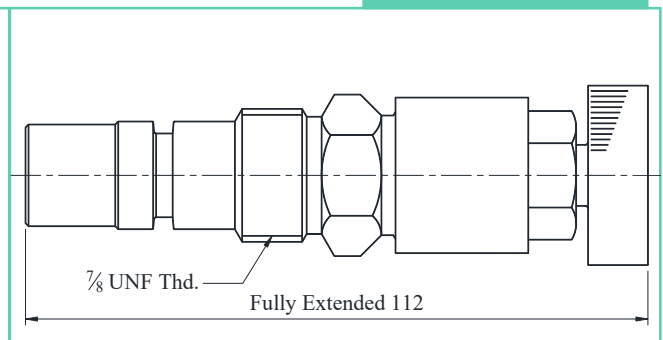
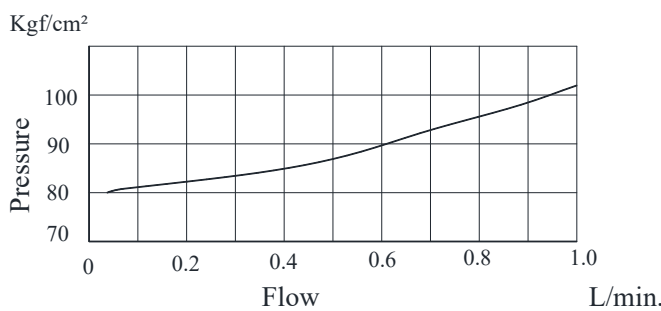

Spare Parts List

List of Seals

Sl. No.	Name of Parts	Parts Number	Qty
1	O-Ring	SO-NB-P20	1
2	O-Ring	SO-NB-P14	1
3	O-Ring	SO-NA-P10	1

Note: When Ordering the seals, please specify the seal kit number KS-CB-1-1080.

Cartridge type Remote Relief Valve

This valve is used in a hydraulic system to prevent damage due to over pressure and to adjust the maximum system pressure of small capacity. These valves can be screwed inside manifold. These valves can also be used as a backpressure valve.

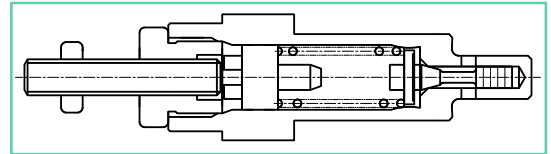

Specifications

Model Number	Max. Operating Pressure Kg/cm ²	Pres. Adj. Range Kg/cm ²	Max. Flow L/min.	Mass Kg.
CB-5-※-※-1080	350	See Model No. Designation	15	1.35

Graphic Symbol

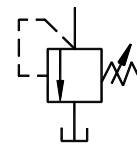

Model Number Designation

C	B	-5	-A0	-1	-10	80
Cartridge Type	Relief Valve	Valve Size	Pres. Adj. Range Kg/cm ²	Type of Operation	Design Number	Design Standard
C	B	5	A0 – 5 ~ 25 A – 7 ~ 50 B – 50 ~ 100 C – 100 ~ 200 D – 200 ~ 350	1. Hand Knob 2. Adjust Screw	10	80

Instructions

- Pressure Adjustment.**
Loosen Lock nut and turn adjustment screw clockwise for increase and anti-clockwise for decrease in pressure. After adjustment set screw with lock nut.
- Care in Application.**
Before the valve is assembled into the manifold, care should be taken to see that inside the manifold dust or chips should not be present.

● CB-5-※ -1-1080

Fully Extended 152

DIMENSIONS IN MILLIMETRES

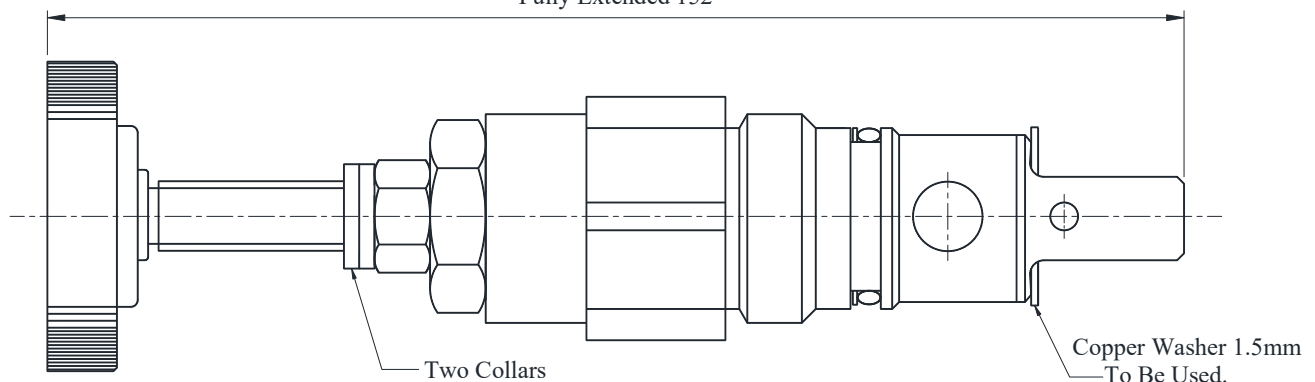

● **CB-5-※-2-1080**

DIMENSIONS IN MILLIMETRES

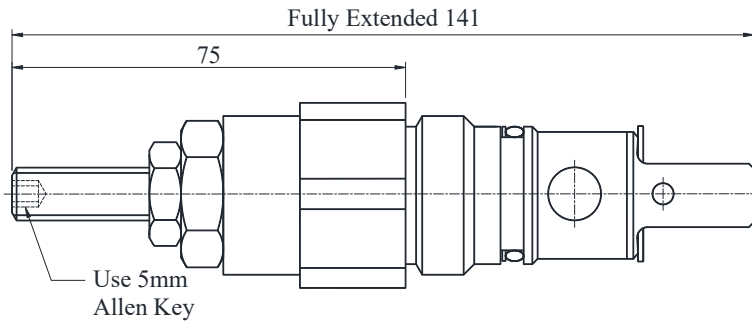

● **Mounting Socket details**

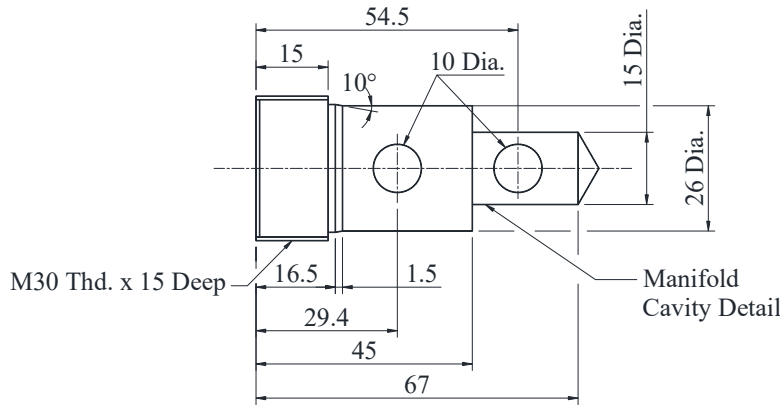

■ **Nominal Override Characteristics**

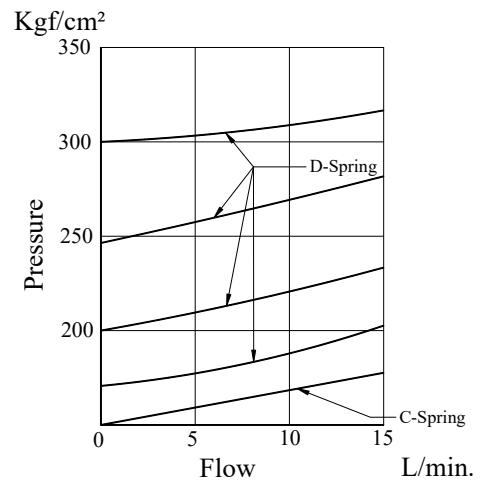
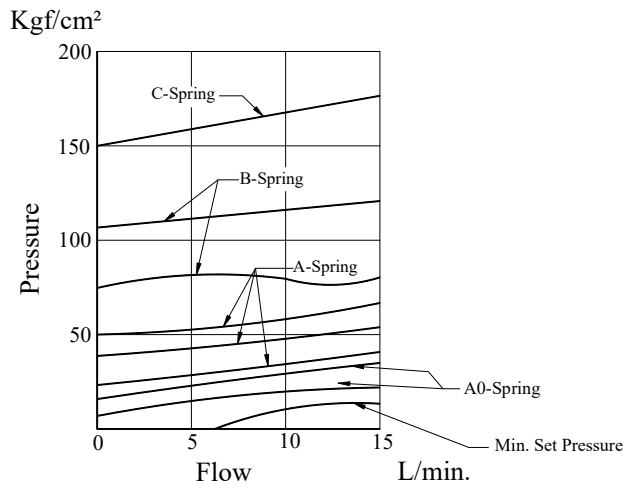

■ **Spare Parts List**

● **List of Seals**

Sl. No.	Name of Parts	Part Number	Quantity
1	O-Ring	SO-NB-P14	1
2	O-Ring	SO-NB-P22	1
3	Backup Ring	SO-BB-P22	1

Note: when ordering the seals, please specify the seal kit number KS-CB-5-1080.

Direct Type Relief Valve

These valves are used in a hydraulic circuit to prevent damage due to excess pressure and to adjust the max. pressure of small capacity.

Graphic Symbol

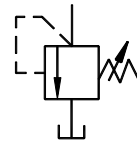

Specifications

Model Numbers	Max. Operating Pressure Kgf/cm ²	Pres. Adj. Range Kgf/cm ²	Max. Flow L/min.	Mass Kg.
B-5-※-※-※-1080	315	See Model Number Designation	30	1.9

Model Number Designation

F-	B	-5	-A	-T	-1	-10	80
Special Seals **	Relief Valve	Valve Size	Spring Type Kgf/cm ²	Mounting Type	Size of Pipe	Design Number	Design Standard
F: Special Seals for Phosphate Ester Type Fluids. (Omit if not required)	B	5	A- 7~50 B- 50~100 C- 100~200 D- 200~315	T: Threaded Connections G: Sub-plate Mounting	1: 1/2 BSP.F 2: 3/4 BSP.F ---	10	80

** Before ordering the Special Seals, consult YUKEN INDIA LTD.

Instructions

- Pressure Adjustment**
Loosen Jam-nut and turn knob clockwise for increase in pressure and anti-clockwise for decrease in pressure.
- Care in Application**
Tank Line of this valve is to be directly connected to tank.

Attachment

- Mounting Bolt**

Valve Model	Socket Head Cap Screw	Qty.	Bolt Kit Ordering Code
B-5-※-G-10	M6 x 50 Lg.	4	BKB5-10

Sub-plate

Valve Model	Sub-plate Model Number	Piping Size	Mass Kg.
B-5-※-G-10	BM-5-1-1080	1/2 BSP.F	2.8
	BM-5-2-1080	3/4 BSP.F	3.8

Spare Parts List

- List of Seals**

Sl. No.	Name of Parts	Part Number	Quantity	
			T-Type	G-Type
1	O-Ring	SO-NB-P14	1	1
2	O-Ring	SO-NB-P22A	1	1
3	O-Ring	AS568-014	-	2

- List of Seal Kits**

Sl. No.	Model	Seal Kit Number
1	Threaded Type	KS-B-5-T-1080
2	Gasket Type	KS-B-5-G-1080

Note : When ordering the seals, please specify the seal kit number from the table at right.

● B-5-※-T-※-1080

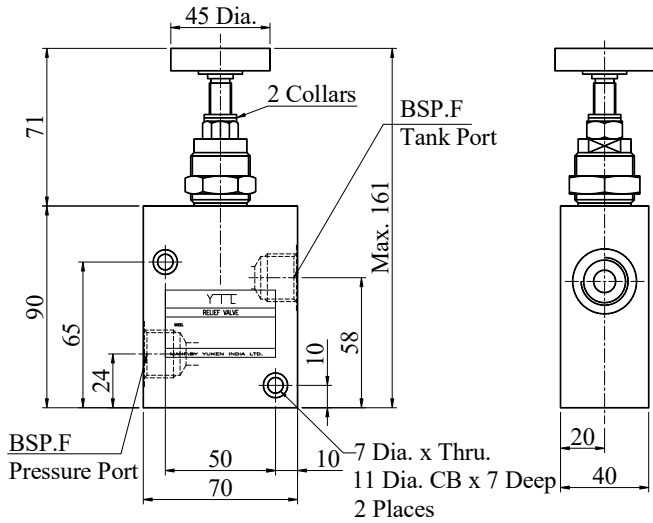

● B-5-※-G-1080

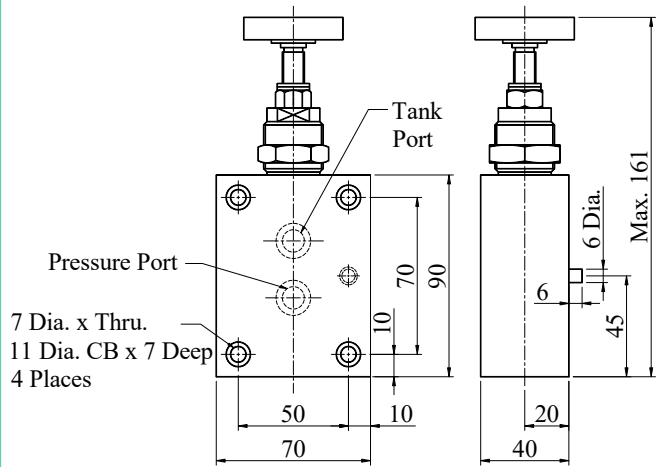

DIMENSIONS IN MILLIMETRES

● Sub-plate: BM-5-※-1080

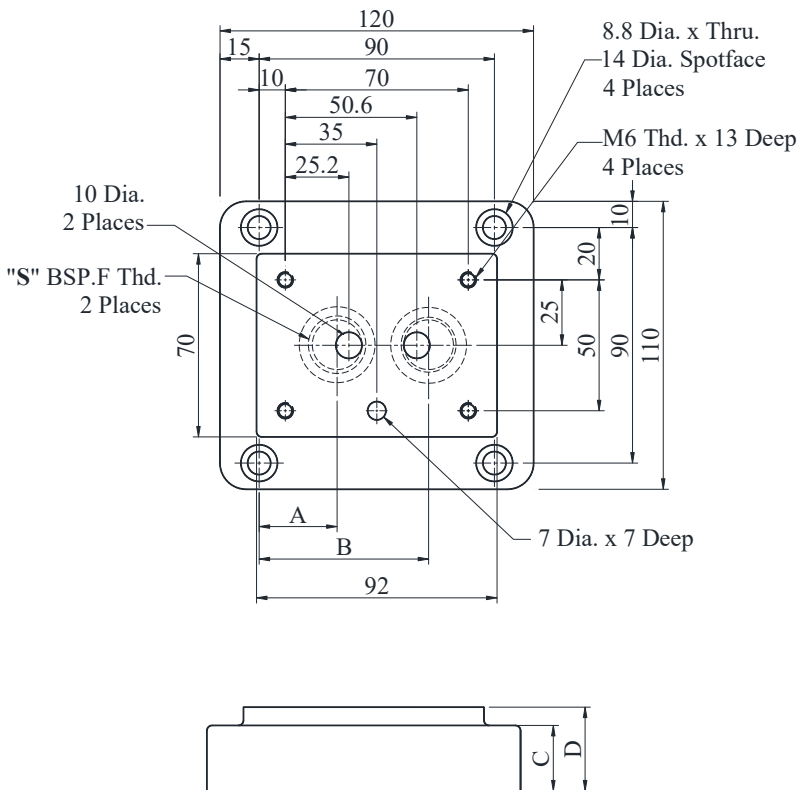

Sub-Plate Model No.	Thread Size "S" BSP.F	A	B	C	D
BM-5-1-1080	1/2	31	65	25	32
BM-5-2-1080	3/4	28	67.6	35	42

■ Nominal Override Characteristics

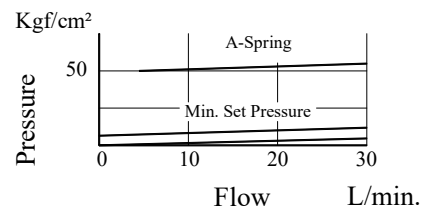
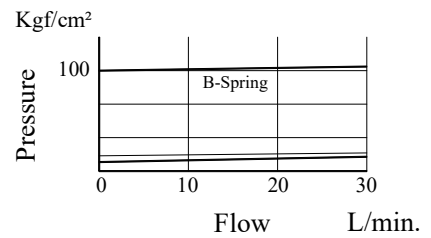
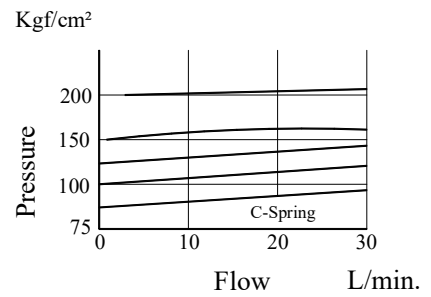
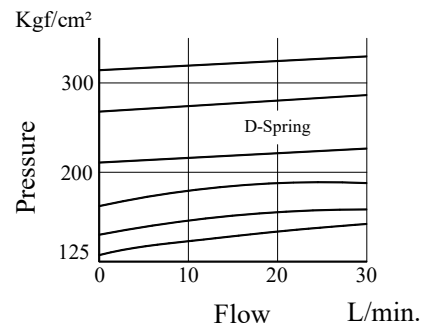

Direct Operated Pressure Relief Valve

These valves are used in a hydraulic circuit to prevent damage due to excess pressure and to adjust the max. Pressure of small capacity. Available sizes NG6 & NG10.

Graphic Symbol

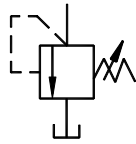

Specifications

Model Number	Max. Operating Pressure Kgf/cm ²	Pres. Adj. Range Kgf/cm ²	Max. Flow L/min.	Mass Kg.
YCB-06	400	See Model No. Designation	50	1.5
YCB-10			120	3.25

Model Number Designation

YCB	-06	-A	-G	-2	-20
Series Number	Valve Size	Max Adj. Pres.# Kgf/cm ²	Type of Mounting	Type of Operation	Design* Number
YCB: Cartridge type Relief Valve	06 10	A0 : 25 A : 50 B : 100 C : 200 D : 315 E : 400	None: Cartridge Type G: Sub Plate Type T: Threaded Type	1 : Adj. Screw 2 : Hand Knob	20

* Design numbers subjected to change, but installation dimensions remains as shown.

Ref. the minimum adjusting pressure characteristics on Page No. 267.

Mounting Bolts

Model Numbers	Socket Head Cap Screw	Qty.	Mounting Bolt Ordering Code
YCB-06-※-G-20	M6 x 35 Lg.	4	BKYCB-06-20
YCB-10-※-G-※-20	M8 x 50 Lg.	4	BKYCB-10-20

Mounting Details

• **Cartridge Type**

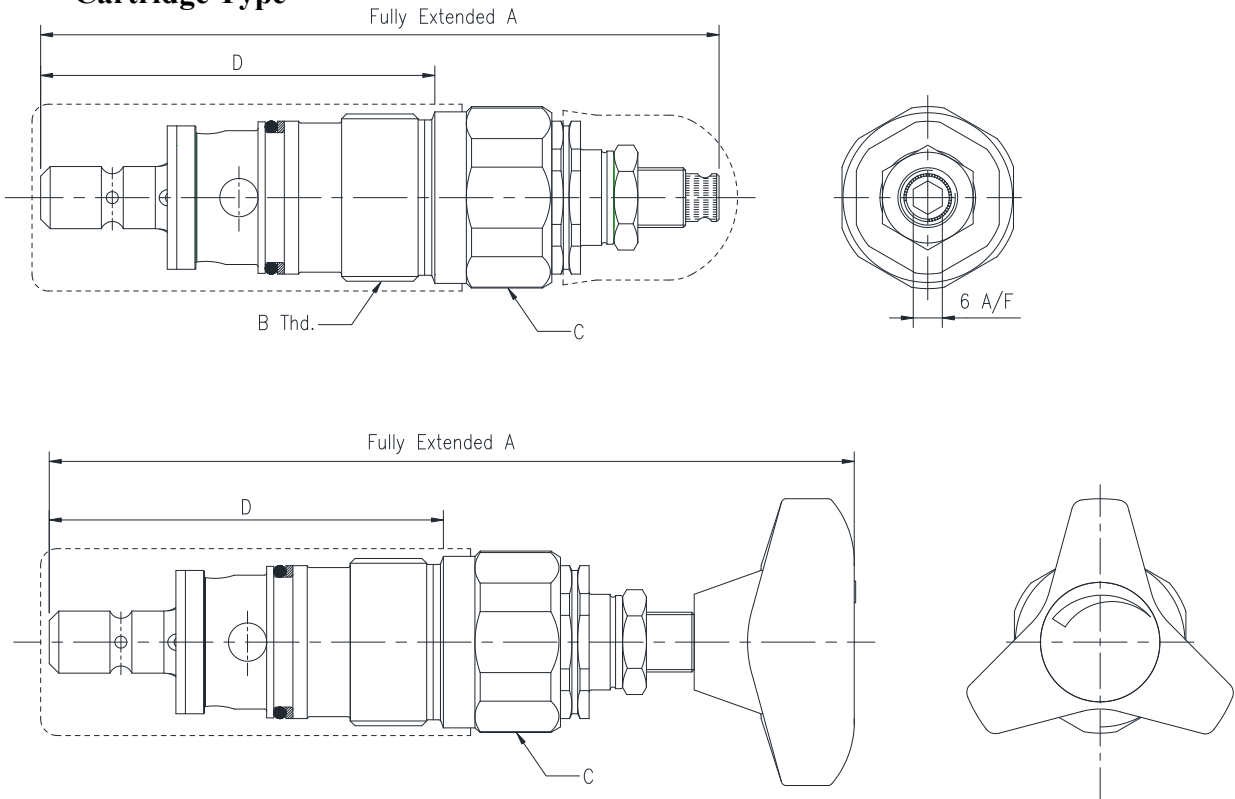

Model Numbers	A	B	C	D	Cavity Details
YCB-06-※-1-20	132	M28 x 1.5	A/F 32	69	Refer Page No. 266
YCB-06-※-2-20	158				
YCB-10-※-1-20	142	M35 x 1.5	A/F 36	82.5	
YCB-10-※-2-20	169				

DIMENSIONS IN MILLIMETRES

• **Sub-plate Type.**

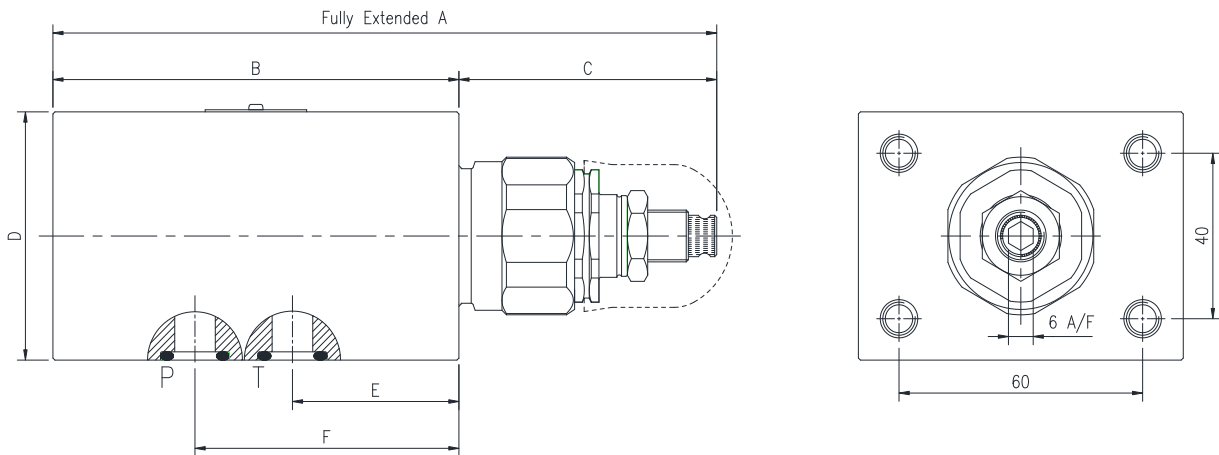

Model Numbers	A	B	C	D	E	F
YCB-06	147.6	80	67.6	40	35	55
YCB-10	164	100	90.3	60	41	65

• Threaded Type

DIMENSIONS IN MILLIMETRES

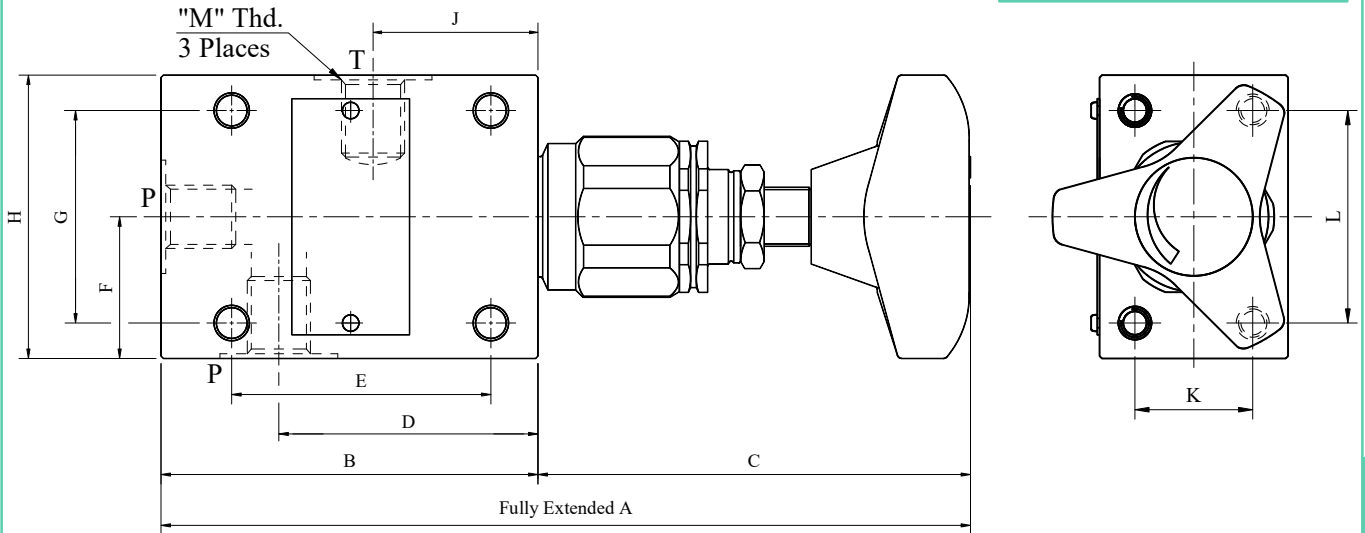

Note : Two optional 'P' ports at 90° to each other are provided. Block the one not in use.

Model Numbers	A	B	C	D	E	F	G	H	J	K	L	M
YCB-06	174	80	94	55	55	30	45	60	35	25	45	1/4 BSP.F
YCB-10	168.5	100	68.5	69	70	40	60	80	41	40	60	1/2 BSP.F

■ Mounting Cavity Dimensions

• YCB-06

• YCB-10

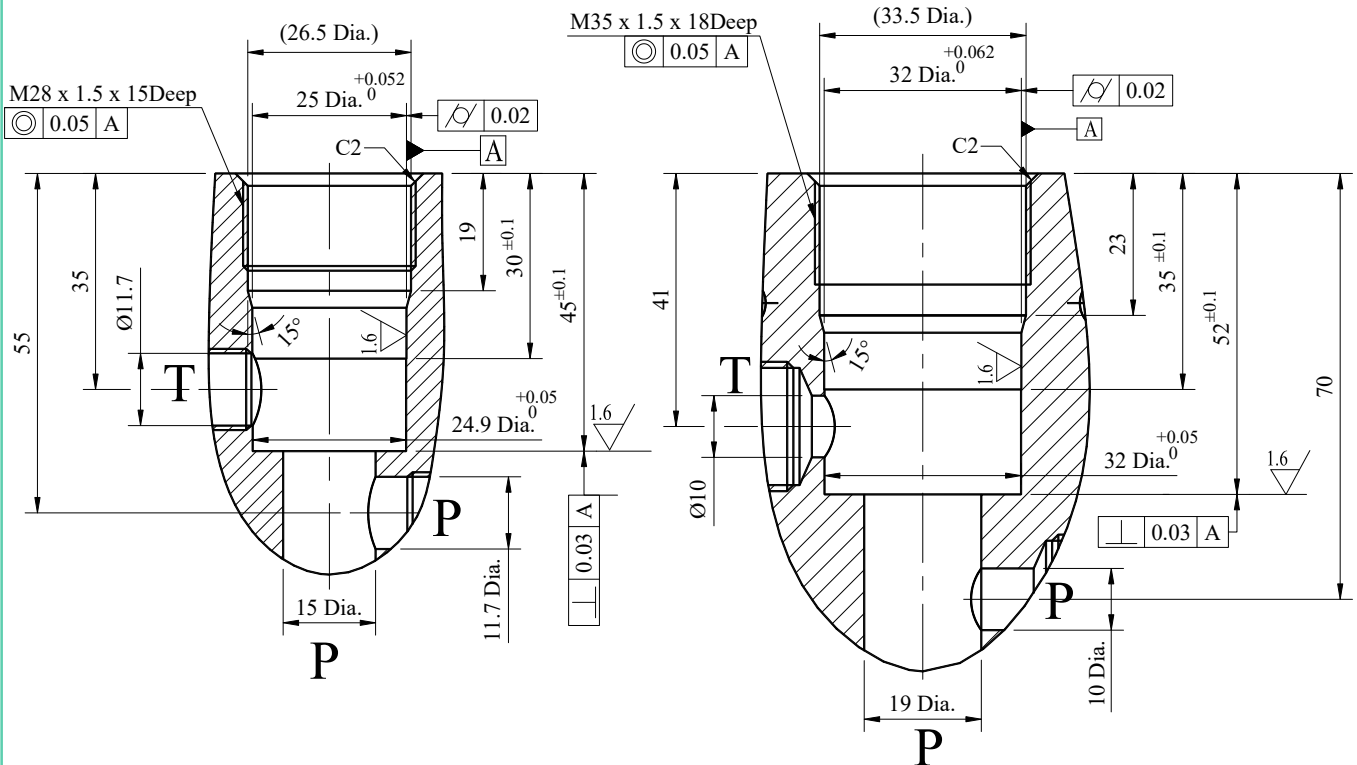

■ Cartridge Mounting Torque in Kgf-cm

Model Numbers	Pressure stage in Kgf/cm ²	
	Up to 200	Up to 400
YCB-06	510	816
YCB-10	1020	1530

Note : Two optional 'P' ports at 90° to each other are provided. Block the one not in use.

C
Direct Operated Pressure Relief Valve

Nominal Override Characteristics

● **YCB-06**

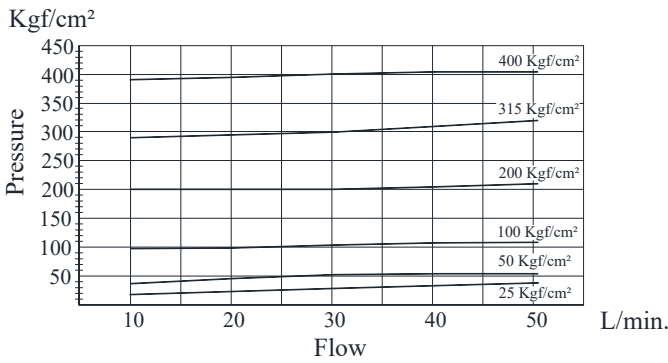

● **YCB-10**

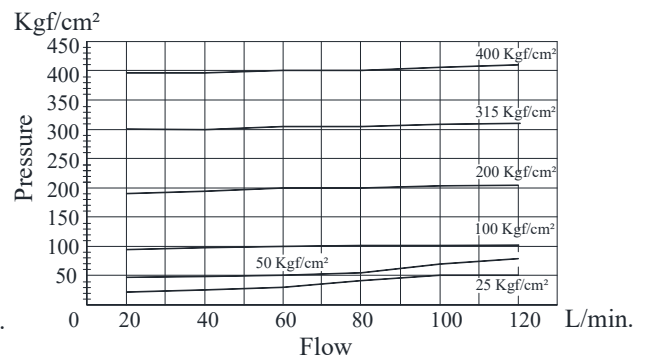

Minimum Adjusting Pressure

● **YCB-06**

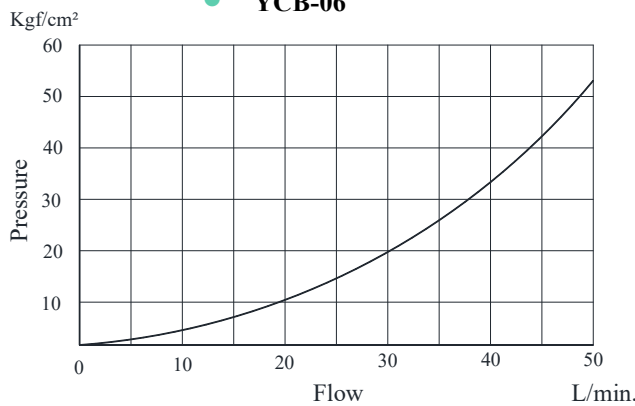

● **YCB-10**

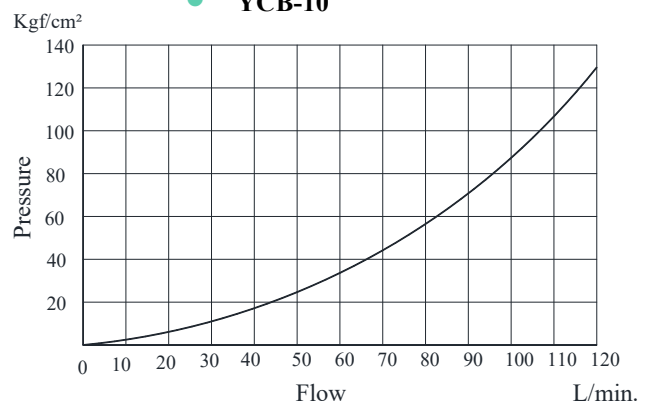

* Curve reflects E-Spring characteristics.

Sub-plate

Valve Model Numbers	Sub-plate Model Numbers	Thread Size	Approx. Mass Kg.
YCB-06-※-G-※-20	YCBM-06-20	1/4 BSP.F	2.5
YCB-10-※-G-※-20	YCBM-10-20	1/2 BSP.F	3.4

DIMENSIONS IN MILLIMETRES

● **Sub-plate: YCBM-06-20**

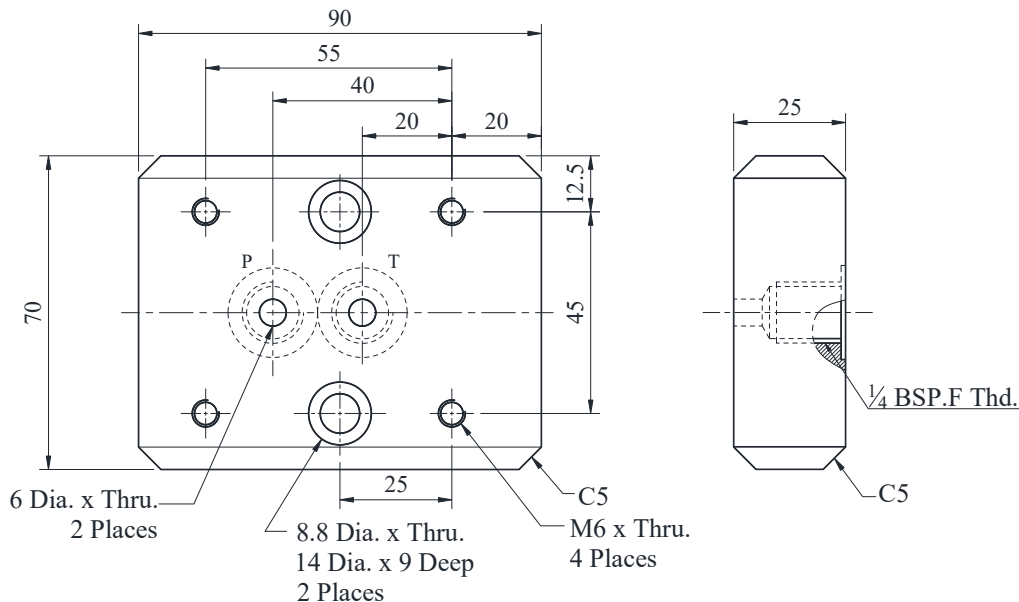

Direct Operated Pressure Relief Valve

● Sub-plate: YCBM-10-20

DIMENSIONS IN MILLIMETRES

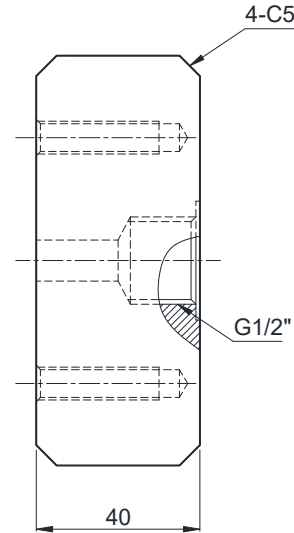
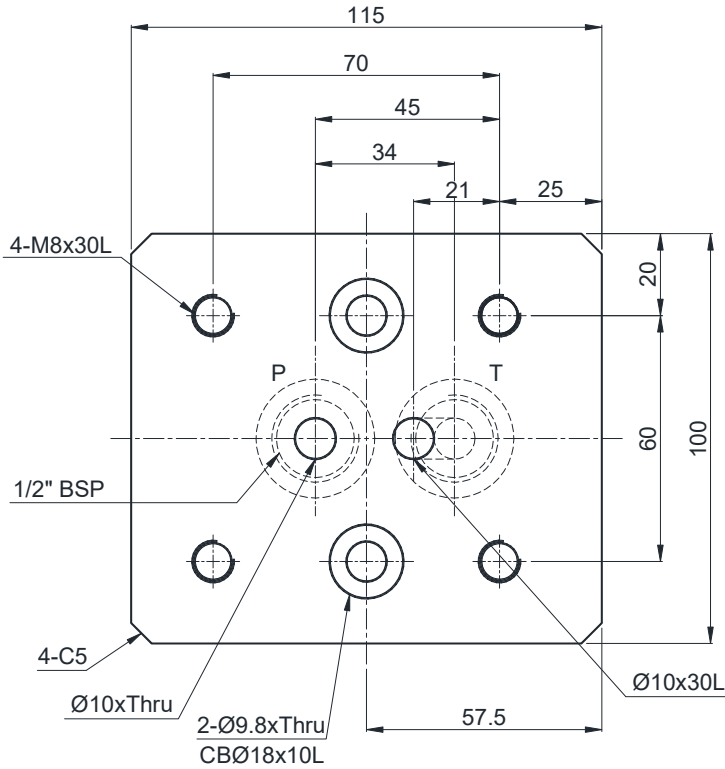

■ Spare Parts List

● YCB-06

● List of Seals

Sl. No.	Name of Parts	Parts Number	Quantity		
			YCB-06	YCB-06-T	YCB-06-G
1	O-Ring	VKH4-1493-0	1		1
2	O-Ring	VKH4-1512-0	1		1
3	O-Ring	SO-NA-P10	1		1
4	Back-Up Ring	SO-BB-P10	1		1
5	O-Ring	VKH4-1507-0	-		2
6	O-Ring	VKH4-1524-0	1		1

Note : When ordering the seals, please specify the seal kit number from the table above.

● YCB-10

Sl. No.	Name of Parts	Parts Number	Quantity		
			YCB-10-	YCB-10-T	YCB-10-G
1	O-Ring	VKH4-1474-0	1		1
2	O-Ring	VKH4-1473-0	1		1
3	O-Ring	SO-NA-P10	1		1
4	Back-Up Ring	SO-BB-P10	1		1
5	O-Ring	VKH4-1513-0	-		2
6	O-Ring	VKH4-1524-0	1		1

Note : When ordering the seals, please specify the seal kit number from the table above.

● List of Seal Kits

Model Numbers	Seal Kit Numbers
YCB-06-※-※-20	KS-YCB-06-20
YCB-06-※-T-20	
YCB-06-※-G-20	KS-YCB-06-G-20

Model Numbers	Seal Kit Numbers
YCB-10-※-※-20	KS-YCB-10-20
YCB-10-※-T-20	
YCB-10-※-G-20	KS-YCB-10-G-20