

Hydro-Electric Pressure Switch

Spring loaded sealed piston construction. Encapsulated design for protection against dirt.

Plug-in connector conforming to DIN 43650 / ISO 4400 for electrical connection.

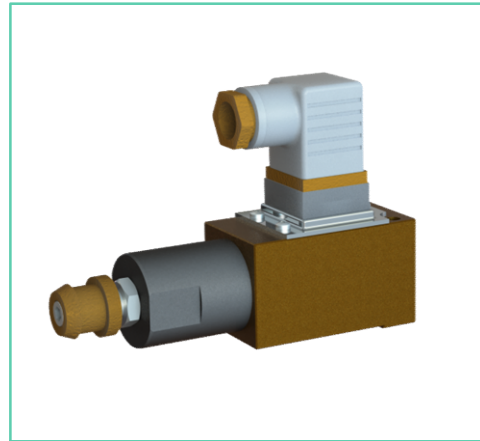

Graphic Symbol

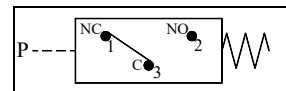

Pressure Setting Ranges

Max. Operating Pressure Kgf/cm ²	Pressure Setting Range Kgf/cm ²
A : 40	5 to 40
B : 100	12 to 100
C : 200	20 to 200
D : 350	30 to 350

Model Number Designation

F-	YS	G	-A	-20
Special Seals **	Series Number	Type of Mounting	Working Pressure Kgf/cm ²	Design Number *
F: Special Seals For Phosphate Ester Type Fluids. (Omit if not required)	YS: YIL Pressure Switch	G: Sub plate Mounting	A: 5~40 B: 12~100 C: 20~200 D: 30~350	20

* Design numbers subjected to change . But installation dimensions remains as shown.

** Before ordering the Special Seals, consult YUKEN INDIA LTD.

Instructions

Pressure Adjustment

Loosen the locknut, then turn the pressure adjustment screw slowly clockwise for higher pressures or anti-clockwise for lower pressures. Retighten the locknut after getting required setting.

Mounting Bolts

Model Number	Socket Head Cap Screw	Qty.	Bolt Kit Ordering Code
YSG -※-20	M5 x 50Lg.	2	BK-YSG-01-20

Spare Parts List

List of Seals

SL.No.	Part Name	Name of Part	Qty.
1	SO-NB-P14	O-Ring	1
2	SO-NB-P9	O-Ring	1
3	OD006005200171A	Step Seal	1

Note : When ordering the seals, please specify the seal kit number KS-YSG-20.

DIN Connector

When ordering the DIN Connector as a spare part, please specify HD-309/S.

■ Connection Diagram

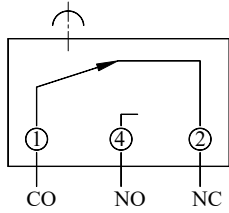

■ Pressure and Micro-Switch Contacts

Pressure	Micro Switch Contact Point	Solenoid
Under the Setting Pressure		ENERGIZED
Above the Setting Pressure		ENERGIZED

■ Switching Pressure Differential

● YSG-A-20

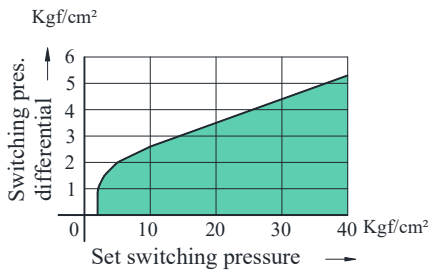

● YSG-B-20

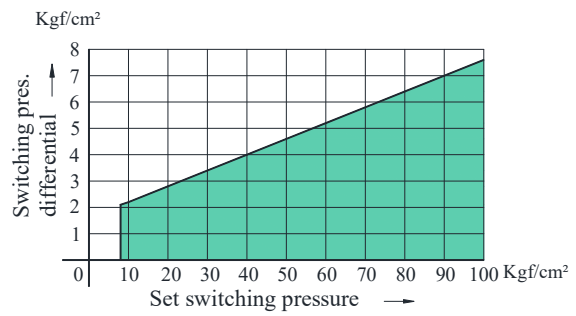

● YSG-C-20

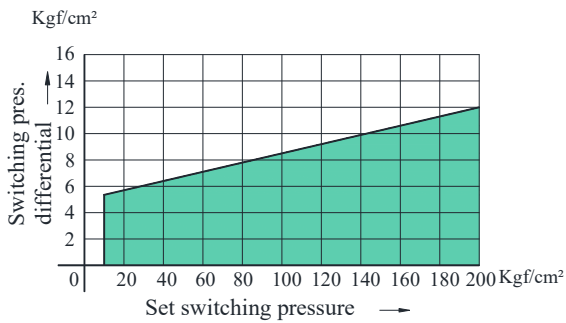

● YSG-D-20

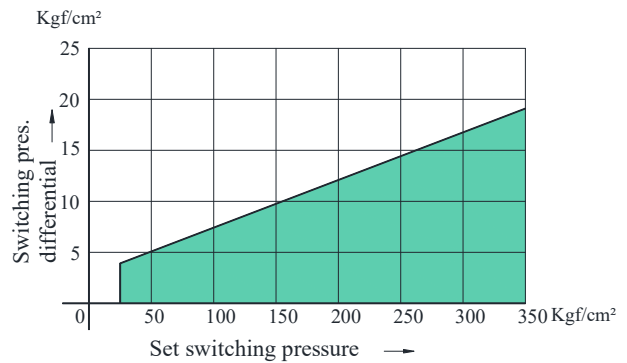

● YSG -※-20

DIMENSIONS IN MILLIMETRES

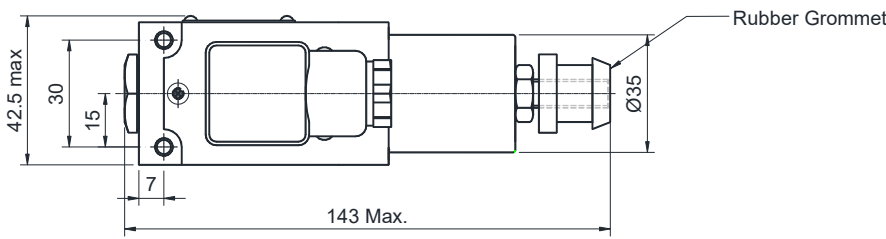
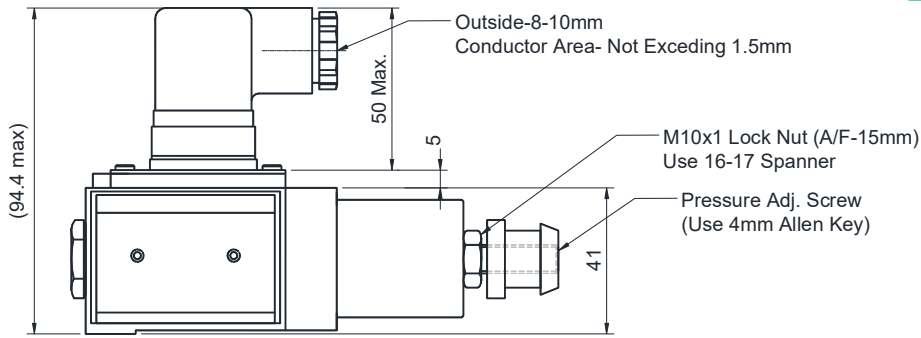

● Mounting Interface

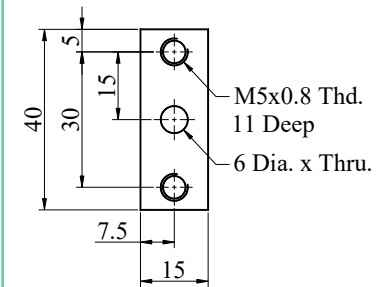

C
Hydro-Electric Pressure Switch

■ Sub-Plate

Model Number	Sub-Plate	Piping Size	Mass Kg.
YSG -※-20	YSGM-01-10	1/4" BSP.F	0.24

● Sub-plate: YSGM-01-10

DIMENSIONS IN MILLIMETRES

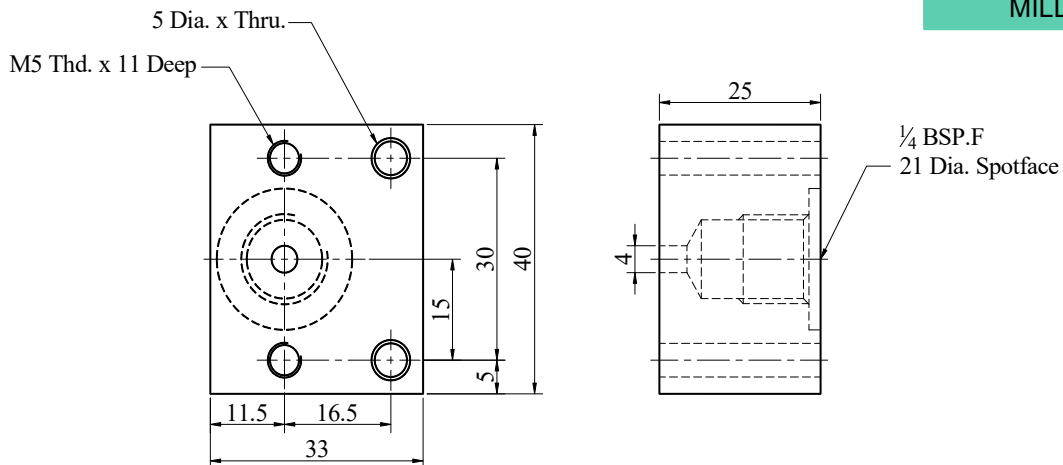

Note: Sub-Plate to be ordered separately Ordering code for sub plate is YSGM-01-10.

